

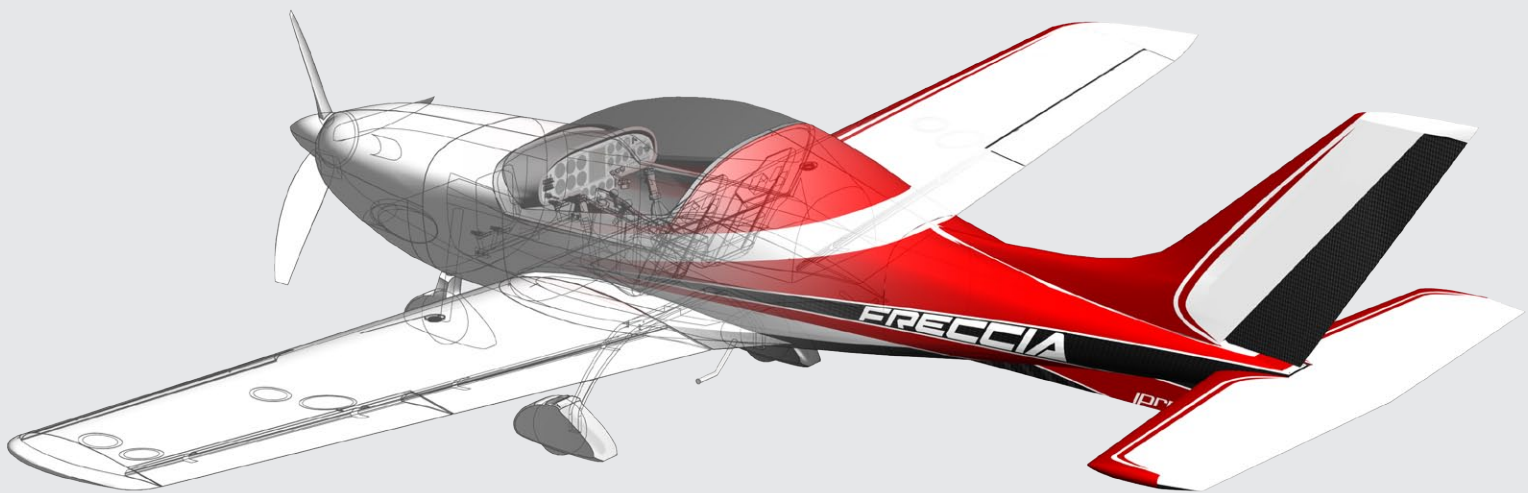

FRECCIA



MAINTENANCE MANUAL

UL-AIRCRAFT LTF-UL 2003

Manufacturer No.: FRXXX

Registration No: D-MXXX

CONTENTS

1. General	5
1.1. Three-view drawings – Freccia	6
1.2. Dimensions.....	8
1.3. Lifetime restrictions	10
1.4. Fuel and other liquids.....	11
2. Technical description	12
2.1. Fuselage	12
2.2. Engine cover.....	13
2.3. Engine mounts	13
2.4. Firewall	14
2.5. Tank	14
2.6. Wings	15
2.7. Empennages.....	16
2.8. Ailerons control	17
2.9. Flaps control.....	19
2.10. Elevator control	19
2.11. Trim control	21
2.12. Rudder control.....	22
2.13. Undercarriage.....	23
2.14. Equipment.....	24
2.15. Primary Flight Display and Engine Monitor System (DEP. CONFIGUR.)....	25
2.16. Electrical System.....	26
2.17. Engine – ROTAX 912 ULS.....	27
2.18. Pitot – static pressure system	31
2.19. Propeller	32
2.20. Brake system	32
3. INSPECTIONS	33
3.1. Scheduled Airplane Inspections.....	33
3.2. Inspection after 5 hours of flight	36
3.3. Inspection after 25 hours (at least once a month)	38
3.4. Inspection after 100 hours of flight (at least once a year)	38
3.5. Lubrication instruction	39

4. Ground Handling	40
4.1. Relocating the Airplane on Ground	40
4.2. Parking.....	41
4.3. Tying Down.....	41
4.4. Lifting and Levelling	42
5. Cleaning and Care	43
5.1. Painted External Surfaces.....	43
5.2. Glass Panels.....	43
5.3. Propeller	43
5.4. Engine	43
5.5. Cabin interior.....	43
6. REPARATIONS	44
6.1. Main wheels' assemblage and disassemblage.....	44
6.2. Replacement of brakes' pads	45
6.3. Replacement of the main wheel's tyre.....	45
6.4. Materials used in manufacturing process	45
7. information signs and Markings	46
7.1. Panel.....	46
7.2. Further markings	47
7.3. Airspeedindicator Marks	47
8. RESCUE SYSTEM	48
8.1. Technical data of the Magnum Light Speed Softpack.....	48
8.2. Installation drawings.....	49
8.3. Maintenance of the Magnum Light Speed Softpack.....	50
8.4. Maintenance during storage	50
9. Weighing Procedure	51

1. GENERAL

This Maintenance Manual is updated regularly. The latest versions can be downloaded as a PDF file on the Web site of the manufacturer (www.promecc.com). The current version number is printed on each page in the header (V ---).

Respect the copyright! This flight manual may not be copied or distributed without the written consent of the originator, not even in a modified form.

MANUFACTURER of the aircraft:

PRO.MECC s.r.l.
Zona Artigianale S.S. 16 - Km 976
73022 - Corigliano D'Otranto (LE)
ITALY

www.promecc.com



As for the engine group's ordinary and extraordinary maintenance, the user must follow the instructions in Rotax manual.



As for the propeller's ordinary and extraordinary maintenance, the user must follow manufacturers operating manual's instructions.



NOTE 1: At the moment for maintenance related to tightening or substitution of detachable match elements you should mark the revised elements with an indelible colour. The colour must be different according to the kind of maintenance (frequency, replacement, tightening, etc.). The legend with the colours which have been used and the kind of maintenance which have been carried out will be included enclosed in the aircraft's maintenance booklet.



NOTE 2: in any case refer to the manufacturer, to specialized firms or to authorized resellers and render a precise account of maintenances.



All major repairs and spare part replacements MUST be done by authorised service personnel.

However, you are encouraged to take care of preventative maintenance yourself.

This includes:

tire and wheel bearings replacements, safety wire replacements, door and safety harness replacement, light bulb replacements, fuel hose replacements, battery servicing and replacement, sparks and spark plugs replacements and air filter replacements.

1.1. THREE-VIEW DRAWINGS – FRECCIA

SIDEVIEW

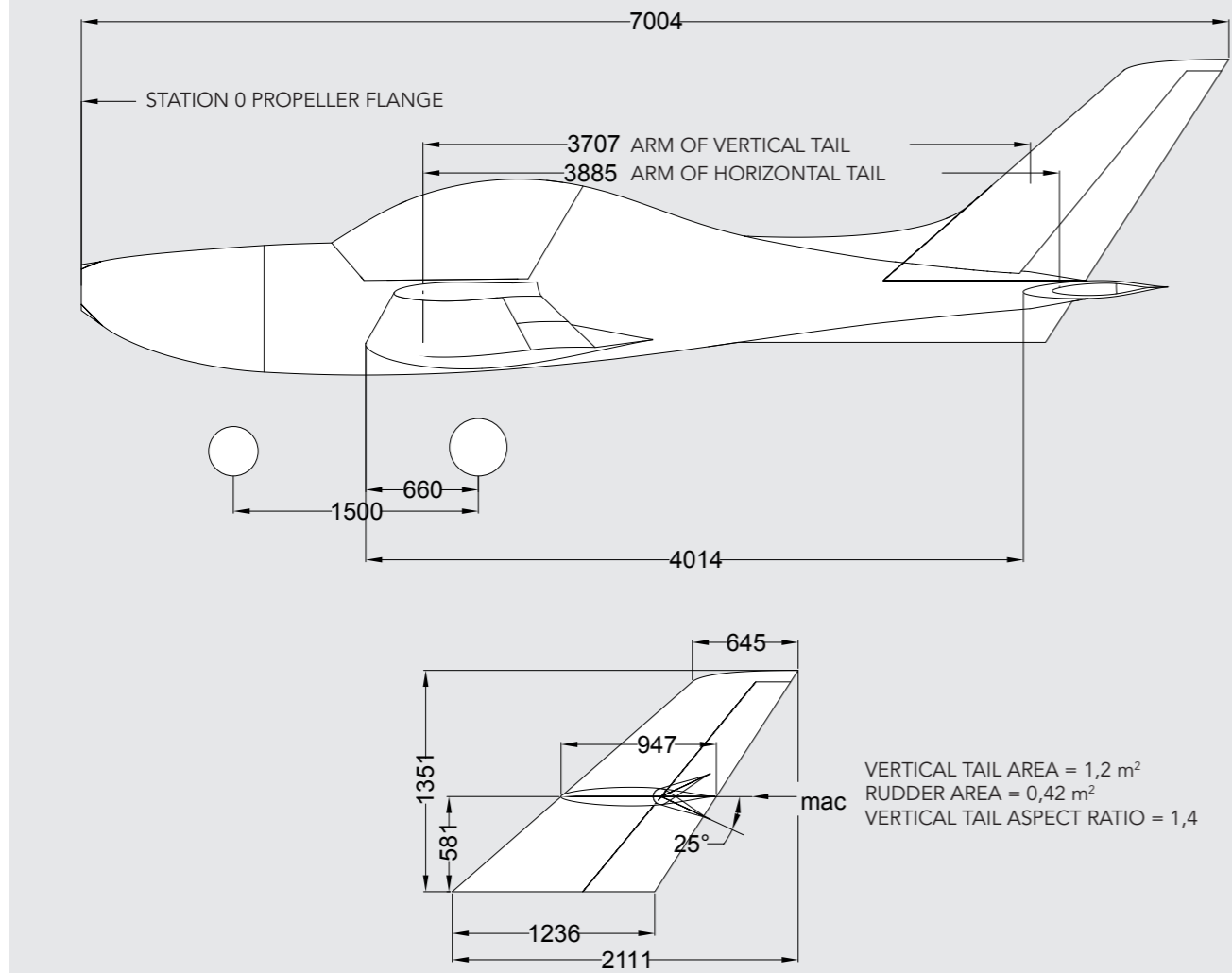

FRONVIEW

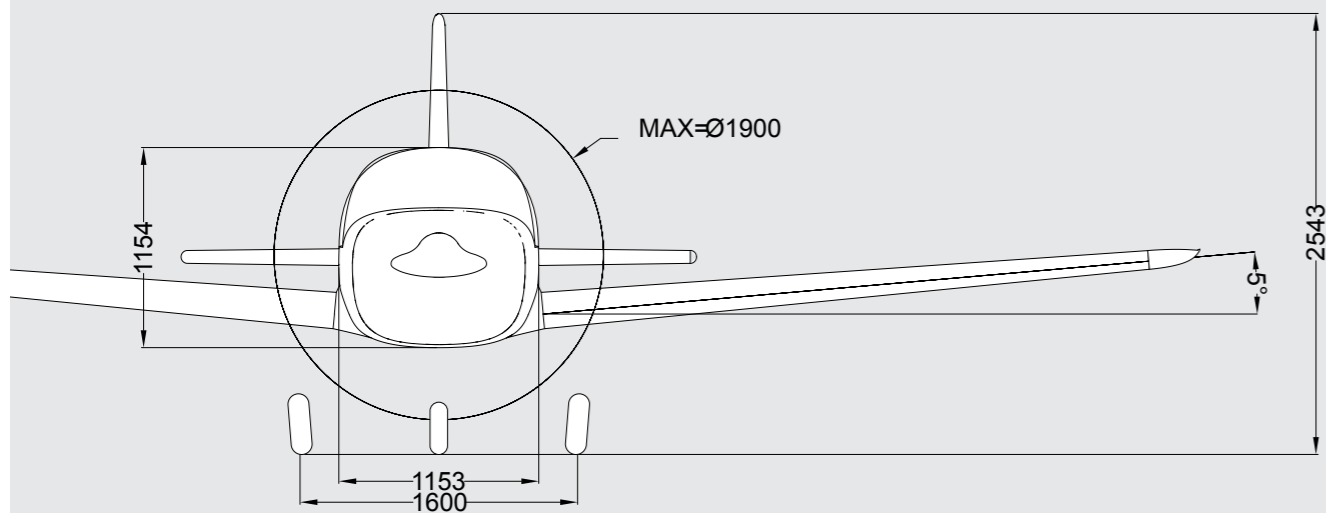

TOPVIEW

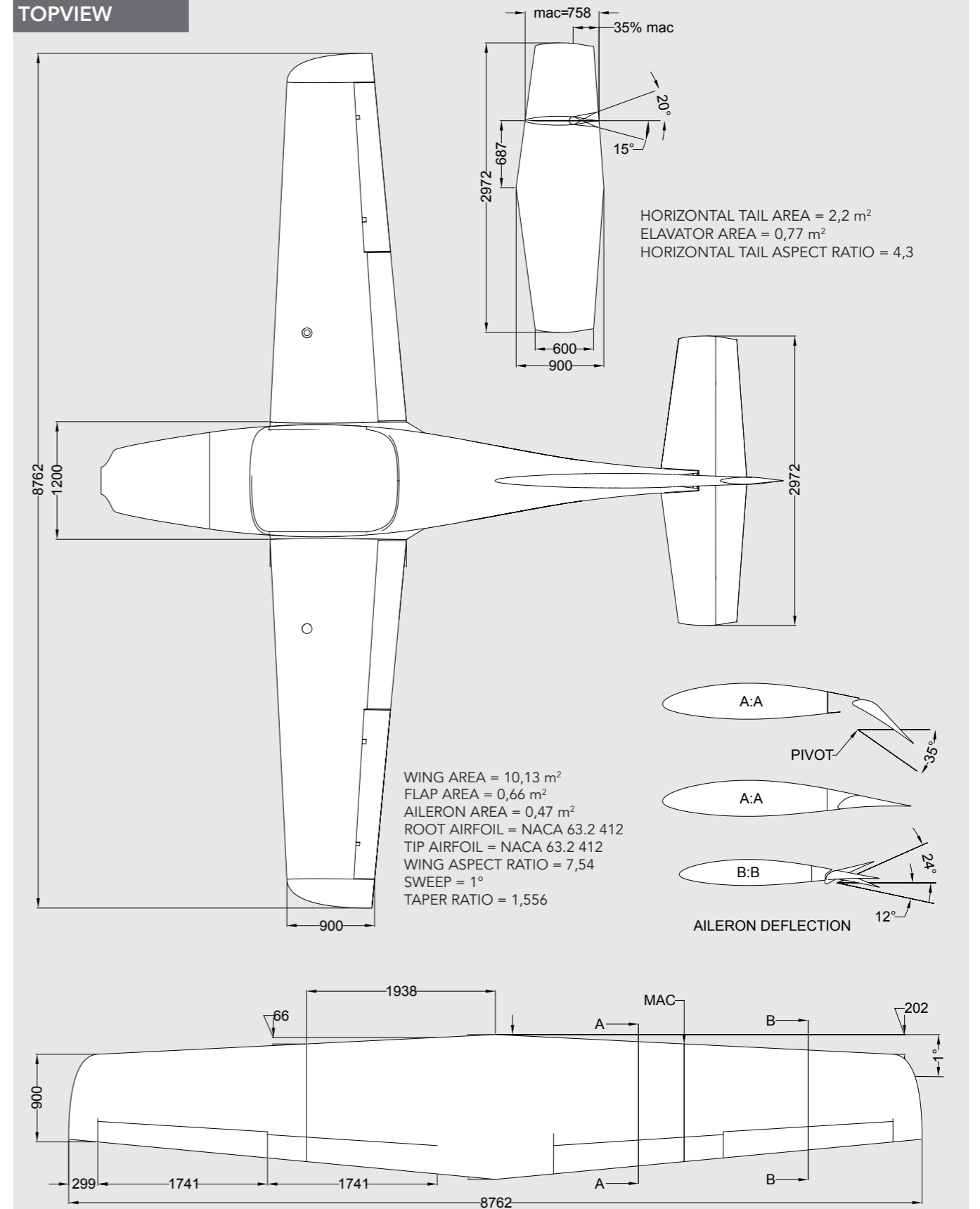

1.2. DIMENSIONS

WING	
Wing span	8,777 m
Wing chord	1,209 m
Wing surface	10,13 m ²
Dihedral	5°

AILERONS	
Aileron span	1,741 m
Mean chord	0,27 m
Aileron surface	0,47 m ²
Steering angle (stroke)	24° ± 1° (up) 12° ± 1° (down)

FLAPS	
Flap span	1,741 m
Mean chord	0,38 m
Flap surface	0,66 m ²
Flaps positions	0° / 35° (down)

FUSELAGE	
Total length	7,248 m
Max width	1,20 m
Max height	2,553 m
Frontal surface	1,20 m ²
Max section surface	1,00 m ²
Fuselage surface crossed by air flow	14 m ²

TAIL PLANE (HORIZONTAL TAIL)	
Wing span	2,972 m
Mean chord	0,758 m
Aspect ratio	2,2 m ²
Extension	4,3
Angle of incidence	+ 1,2

ELEVATOR	
Elevator span	2,972 m
Surface	0,77 m ²
Stroke	20° (up) 15° (down)

TRIM	
Width	0,75 m
Chord	0,075 m
Stroke	20°±2° (up) 20°±2° (down)

VERTICAL FIN	
Vertical fin span	1,351 m
Minimum chord	0,645 m
Maximum chord	1,236 m
Mean chord	0,947 m
Surface	1,12 m ²
Extension	1,4

RUDDER	
Surface	0,42 m ²
Steering angle	±25° ± 1°

ENGINE	
Engine model	ROTAX 912 ULS
Maximum rotational speed of the propeller	2400/2800 according to the engine model
Maximum rotational speed of the engine	5800 rpm in 5min / 5600
Propeller	According to the customer's demand

UNDERCARRIAGE	
Width of the rear landing gear (undercarriage)	1,6 m
Distance between the turning wheel and the rear landing gear	1,5 m

1.3. LIFETIME RESTRICTIONS

General overhauls are fixed on 1200 flight hours or 10 year of use.

As for the engine and some special elements, refer to the following table:

ENGINE, SYSTEM, PART	LIFE SPAN	SPARE PART REPLACEMENTS
ROTAX 912 ULS ENGINE	First overhaul: after 1500 hours or 15 year of use	End of potential
Propeller	See manufacturer's user manual	End of potential
Engine fittings	According to engine manual or in accordance with their state and condition.	End of potential or wear and tear
Fuel filter	100 h	End of potential
Battery	2 years	End of potential
Fuel and oil sleeves	According to their state and condition	Wear and tear, damage
Engine mounts and main undercarriage plate's silent-blocks	According to their state and condition	Wear and tear, damage
Fuel pump	According to their state and condition	Breakdown
Brake small pads	According to their state and condition	Breakdown
Brake disc	According to their state	Breakdown
Life-saving equipment (if it's present)	See manufacturer's user manual	See manufacturer's user manual
Tyres	According to their state and condition	Wear and tear, damage
Tools	According to their state and condition	Breakdown

As the previous table, some elements and subsets must be overhauled or replaced in the aircraft's lifetime. The technical staff who guarantee the use of the aircraft must check frequently these elements' good conditions and dependability and they must replace them, according to their state and condition.

Any yielding found out in the use must be put right, and every parts where some yieldings have been found must be checked carefully.

The list of the elements and the subsets which are subject to replacement is quoted in the engine manuals.



The replacement and installation techniques of the aircraft's other elements and subsets are quoted in the respective chapters.

1.4. FUEL AND OTHER LIQUIDS

CAPACITY

ENGINE COOLING SYSTEM	
Cooling fluid capacity	2,160 l
Radiator volume	0,600 l
Engine cooling cavities volume	1,410 l
ENGINE LUBRICATION SYSTEM	
System total volume	3 l
BRAKING SYSTEM	
System total volume	0,150 l

FUEL, OIL AND OTHER LIQUIDS

FUEL
Car fuel, at a 90-octane rating for ROTAX 912UL, at a 95-octane rating for ROTAX 912 ULS.
 REMARK: the use of leaded petrol is forbidden!
OIL
Synthetic motorcycle oil from 50W-40 to 20W-50, according to the respective ambient temperature.
 REMARK: The use of oil additives is forbidden!
COOLANT
Car anti-icing used for aluminium-alloy engines.
BRAKE FLUID
Car brake fluid.

2. TECHNICAL DESCRIPTION

This Section contains a description of the airplane and its equipments.

2.1. FUSELAGE

Fuselage is made up of a shell-like structure in carbon fibre (epoxy resin). Fin is an integral part of the fuselage.

Wing attaching points are made up of 2 carbon fibre spars going through the shell.

Engine mounting pylon is made up of welded steel tubes. The engine is separated from the fuselage by means of a firewall protection.

Cockpit seats are positioned side by side and their shape is rigid and ergonomic, not adjustable. Safety belts have three junction points and are adjustable and provided with a single lock easy to unfasten. The baggage compartment is located behind pilots seats, it is allowed to transport a maximum of 10-kg. A Plexiglas canopy can be opened lifting.

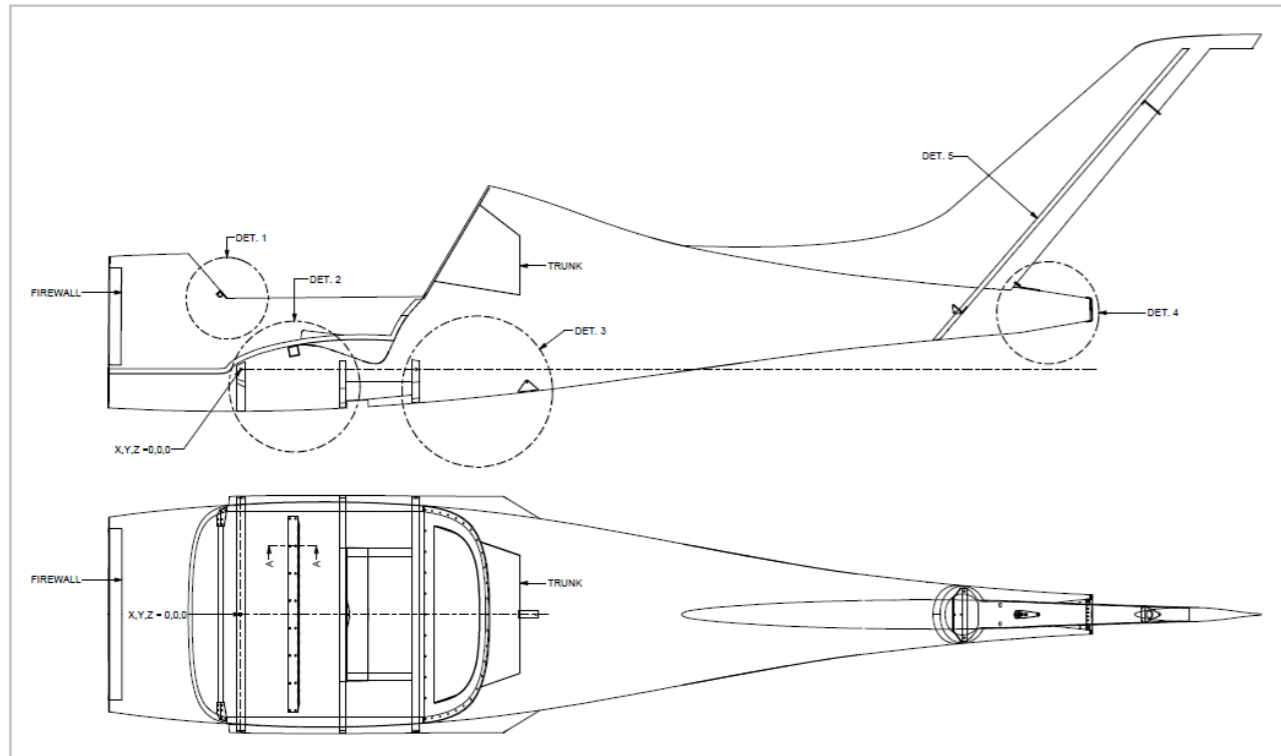

2.2. ENGINE COVER

The engine is covered by a cover made of a top part and a lower one. The two pieces are fixed to the fuselage and are fixed each other through collblock.

In the lower part of the cover there are the air intakes to cool the engine.

ENGINE COVER

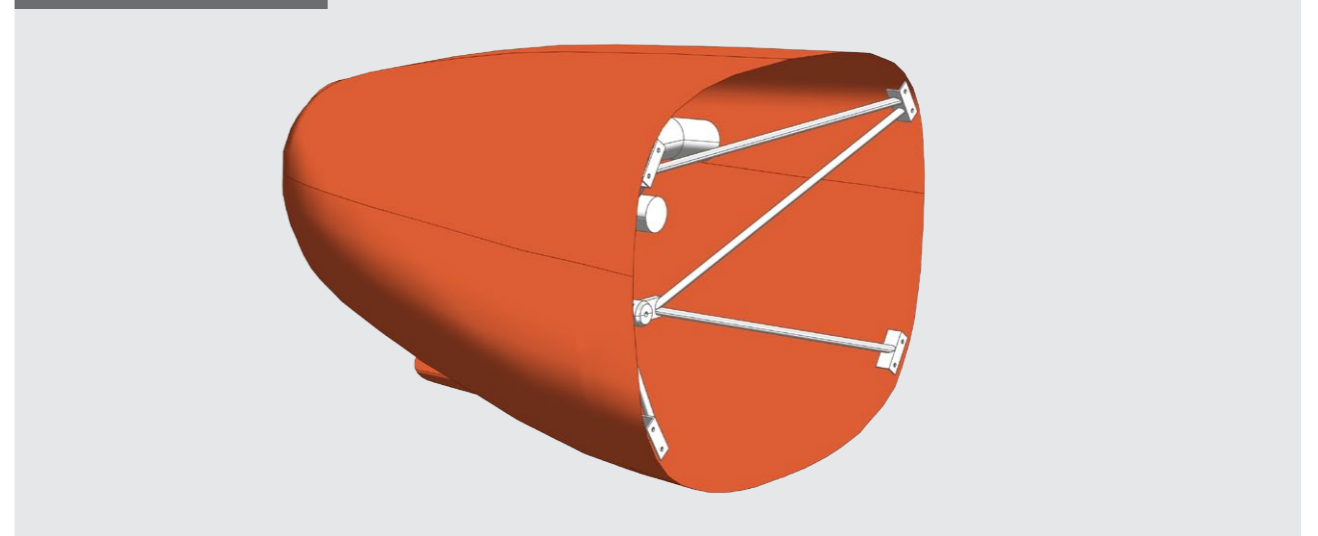

2.3. ENGINE MOUNTS

The engine mounts are made of a three-dimensional frame with steel tubes.

The engine mounts have the fittings with the fuselage and the engine through bolts and rubber silent blocks.

The oil radiator and cooling-fluid radiator are installed on some props.

The order of radiators' installation in the engine systems is explained in the engine manual.

ENGINE MOUNTS

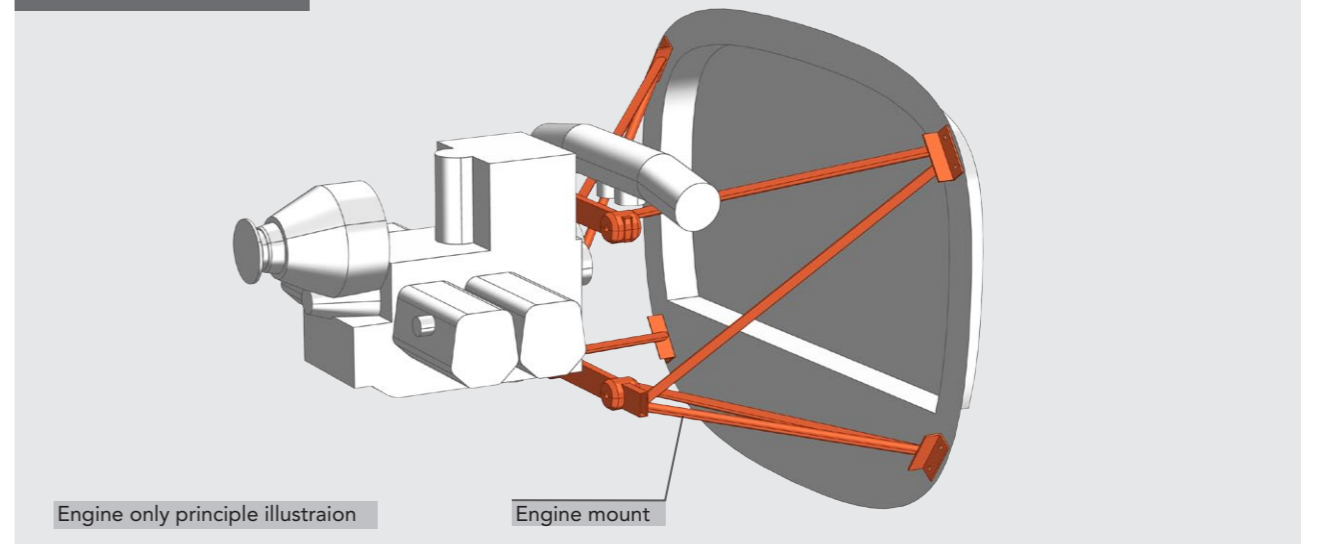

2.4. FIREWALL

The firewall is a structural element situated on the front part of the fuselage and it separates the engine from the cabin. It's made of a composite-material panel. The part of the panel which is turned to the engine has the attachment fittings for supporting the battery case, for the oil tank and for other components of the power plant and the aircraft systems.

The firewall is covered by a special material heat and flame resistant.

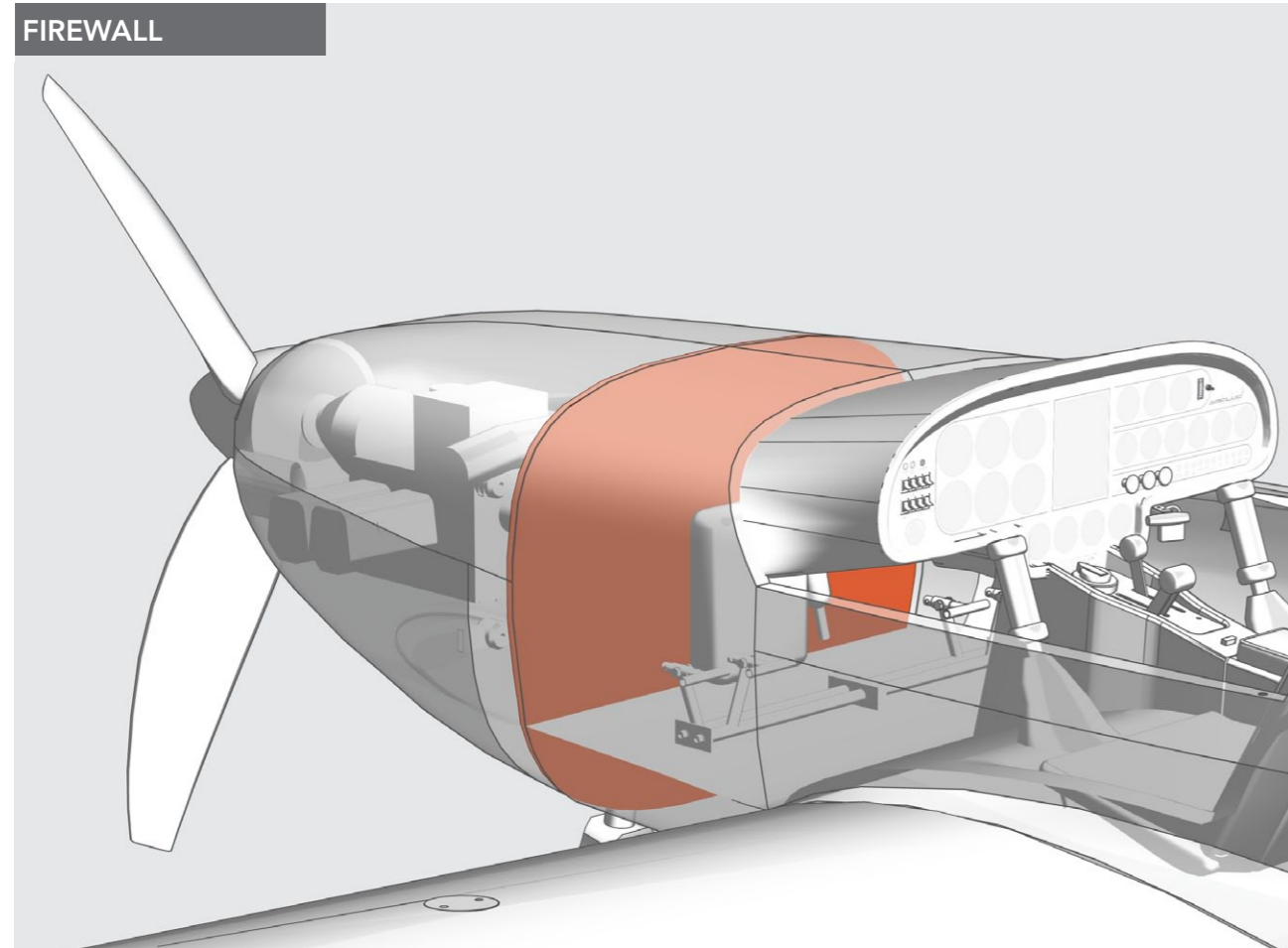

FIREWALL

2.5. TANK

The tanks are made of fibreglass and are in the right and left wing-halves. At the rear they have a cylindrical screwing which is set in the hole rib; on the front it is secured to aluminium ribbing.

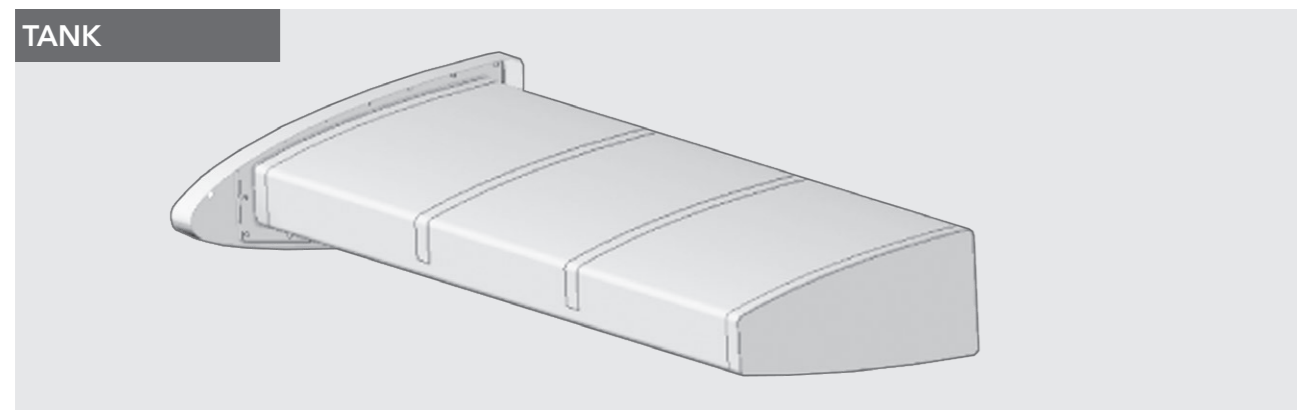

TANK

2.6. WINGS

The aircraft is provided with a low and tapered wing made up of 2 half-wings in carbon fibre that can be disassembled, with a main spar going through the fuselage and with a wing rib equipped with wing-fuselage connection points. Wing tips can be removed.

The structure of wing, flap and aileron is identical to the one of tail unit.

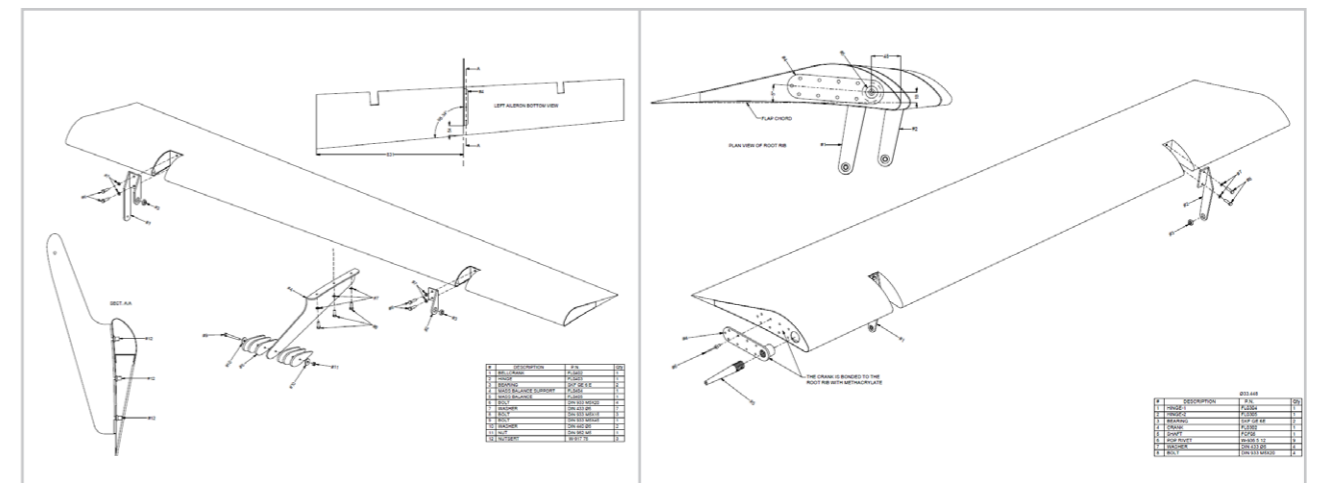
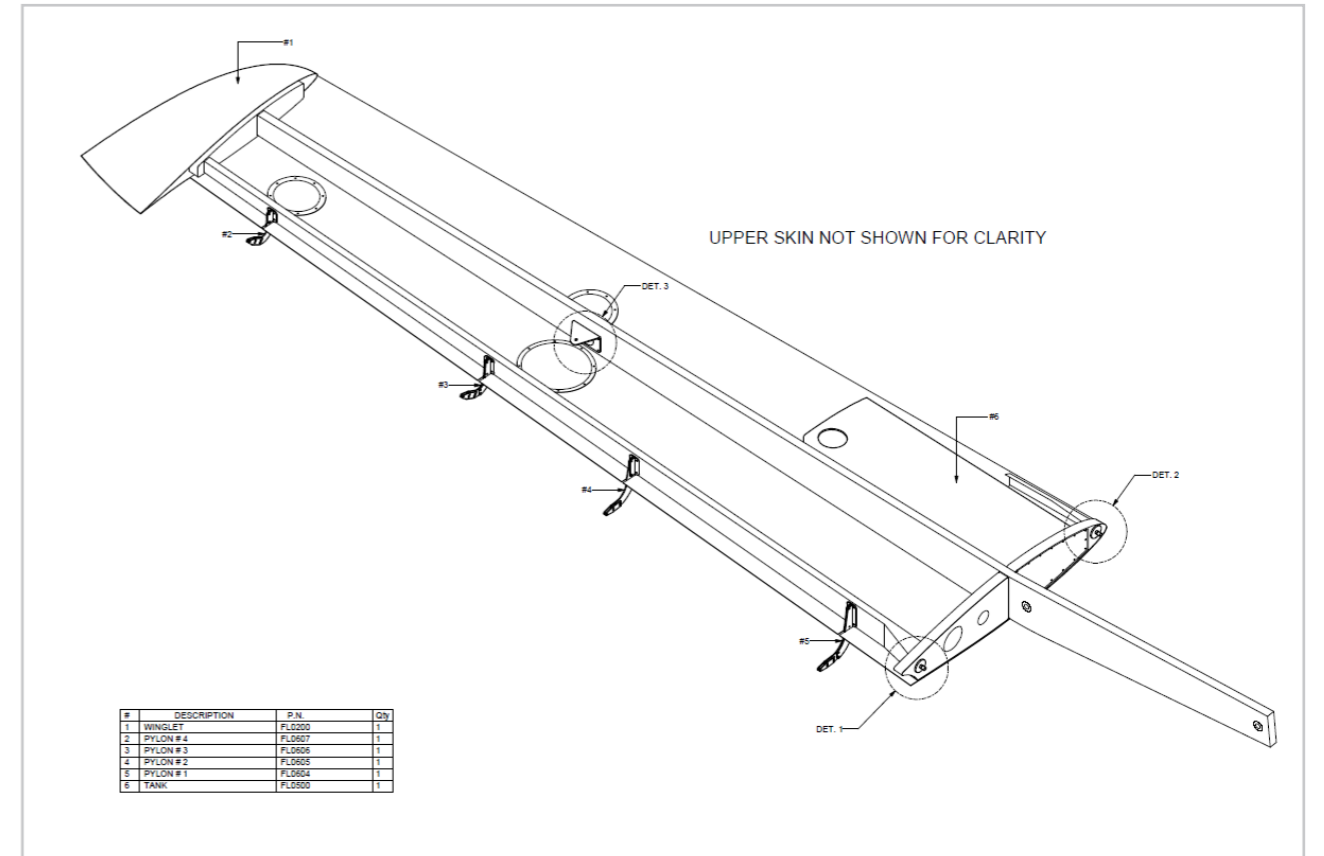

2.7. EMPENNAGES

Classic type and provided with rudder, tail plane, elevator and trim electrically moved.

It is made of composite materials with a shell of sandwich panels composed of carbon glass fibre and p.v.c. and the spar made of p.v.c.-carbon fibre.

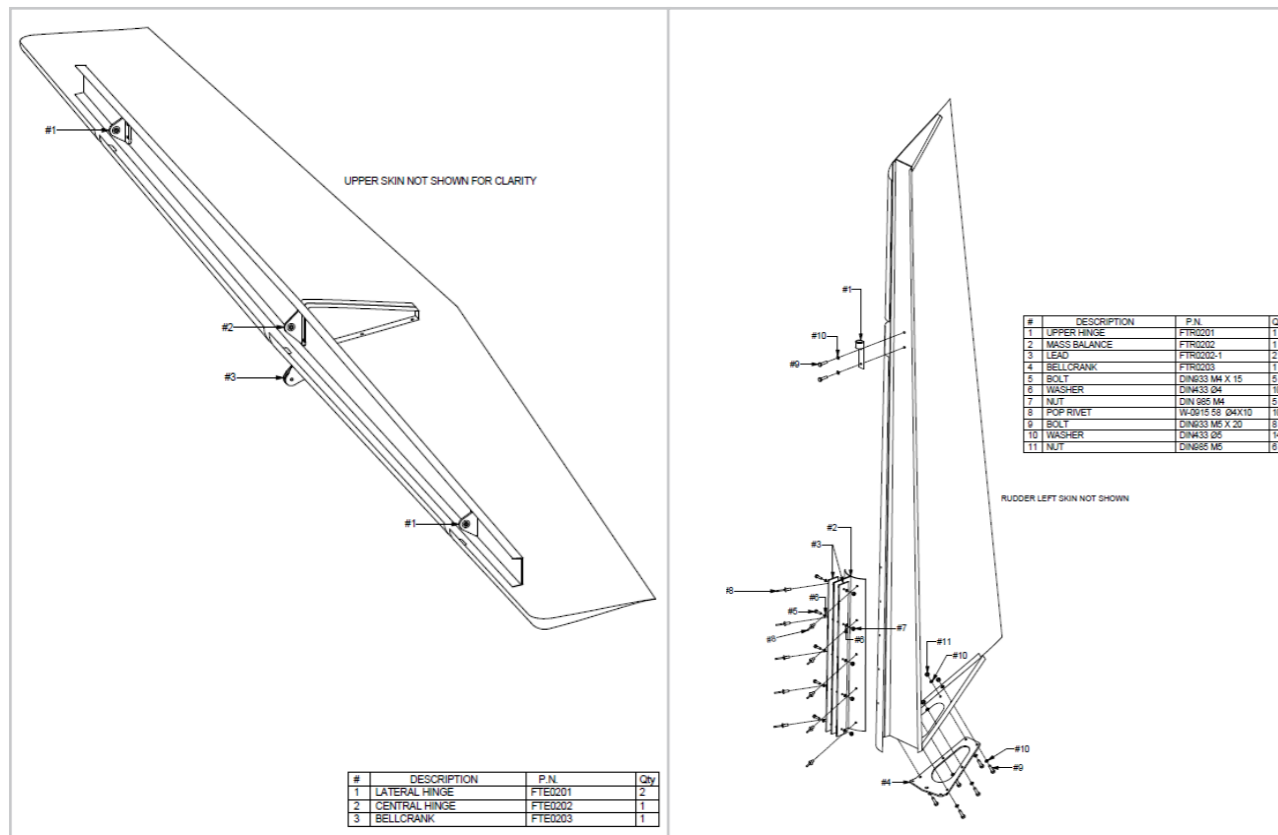
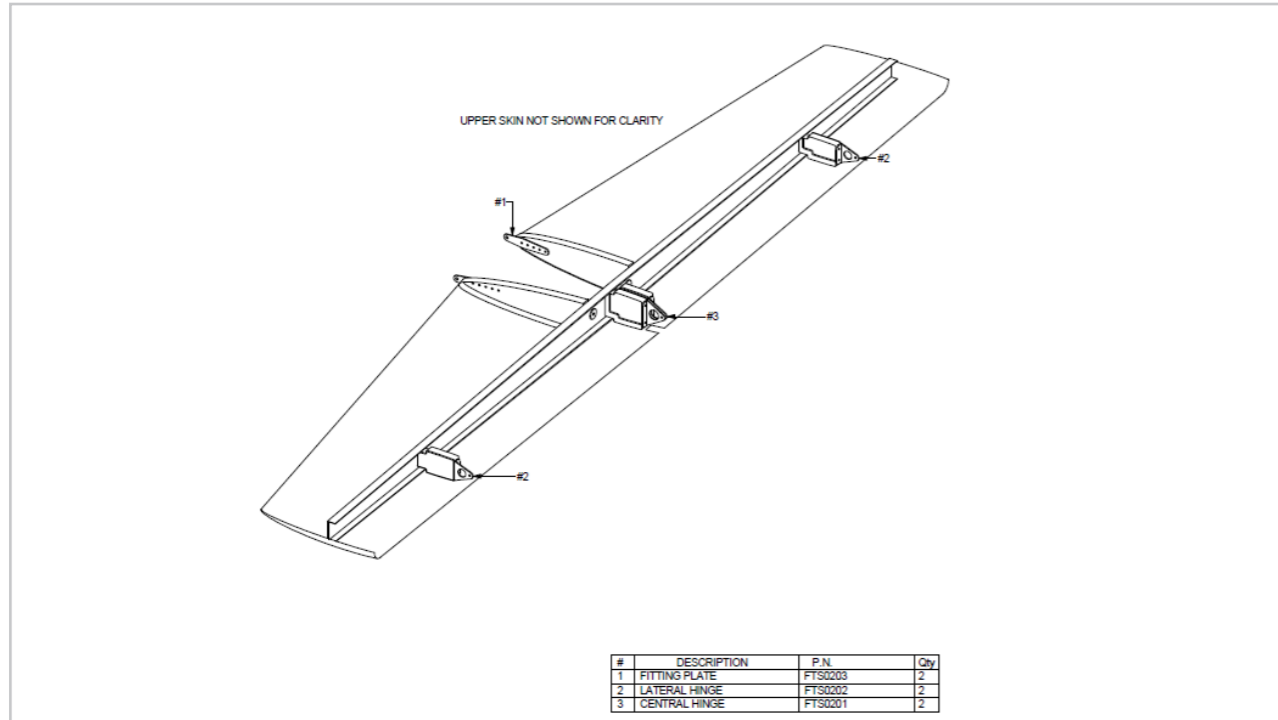

2.8. AILERONS CONTROL

The ailerons control is differential (when the right aileron moves upwards, the left one goes downwards and vice versa). The angle of steering on the upwards is wider than the angle of the one downwards.

The aileron course compared to neutral position is of $24^\circ \pm 1^\circ$ upwards and $12^\circ \pm 1^\circ$ downwards. The consequence is the increase of ailerons' efficiency especially in the big-incidence flight, also to make up for the different curvature between the back and the underside of the wing.

Replaced through connecting rods and transfers, they efforts on the control handle are passed on the wing. The controls assembly connects the right control stick with the left one and vice versa. From each of them a transfer is connected to the respective wing through an extensible-head connecting rod. From that a bar inside the wing transmits the movement to the last transfer, integrated into one of two aileron hinges.

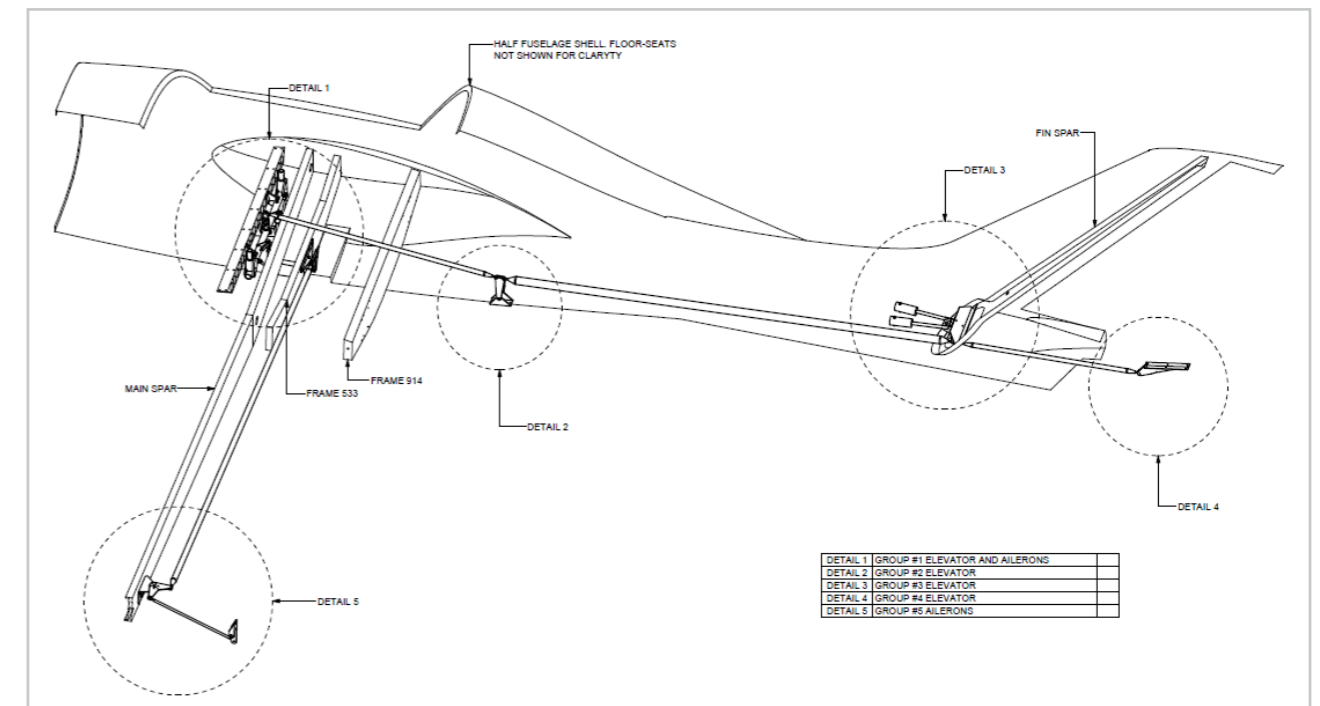

Rigging of Ailerons Control

In a neutral position the ailerons' aft edge must be on the same line as the back part of the wing tip; the maximum admissible difference upwards or downwards is of 2 mm.

Check if the positions at the end of ailerons running are correct. If it isn't, follow these steps:

- 1 Put the aileron upwards;
- 2 Loosen the push-rod locknuts which are under the wing. Act on the internal nut, by unscrewing top up the aileron up or by screwing top up it down, until its trailing edge has the indicated distance from the tip's aft edge (limit switch upwards).
- 3 Consequently the limit switch downwards is correct thanks to the aileron's transfer design.
- 4 Screw and lock the external checknut.

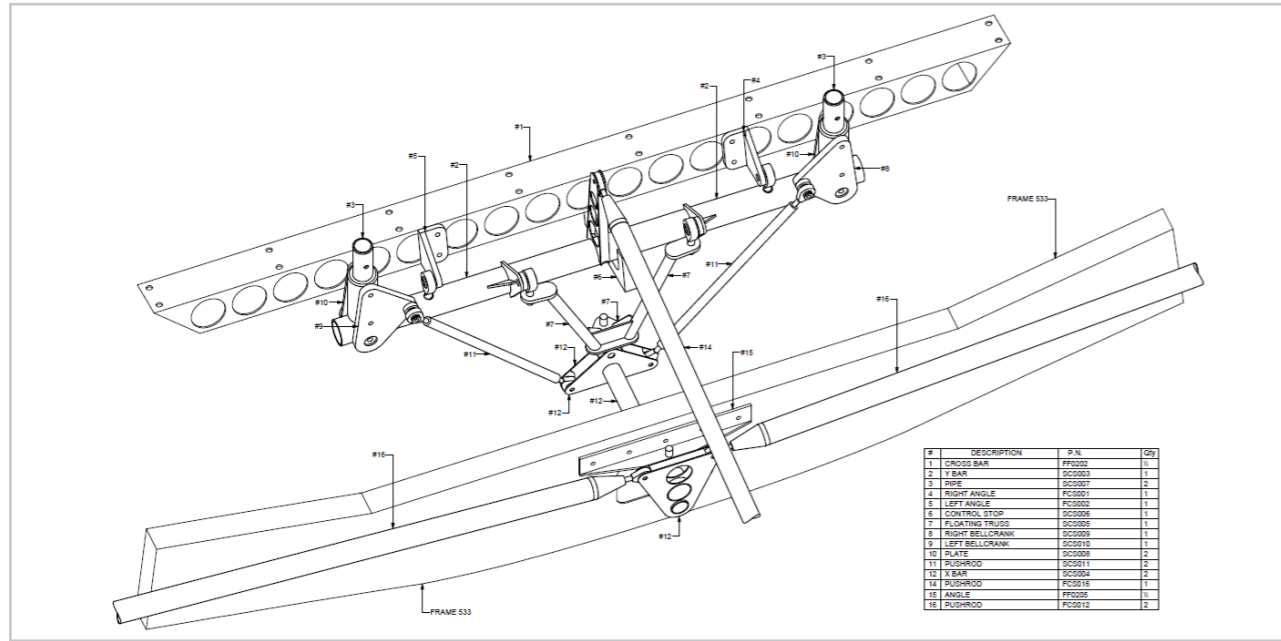

Control-stick adjustment

If the control stick is in a neutral position and the ailerons are not lined up with the respective tips, act as follows:

- 1 Remove the door on the seats's floor;
- 2 Unscrew the M6 nut to take off the connecting rod from the control-stick transfer;
- 3 Fix the aileron and the control stick in a neutral position;
- 4 The connecting rod goes up an adjustable head: unscrew the control for some turns and rig the head until it can enter easily in the control-stick bolt;
- 5 Screw again the M6 nut and lock the checknut;
- 6 Close the door.

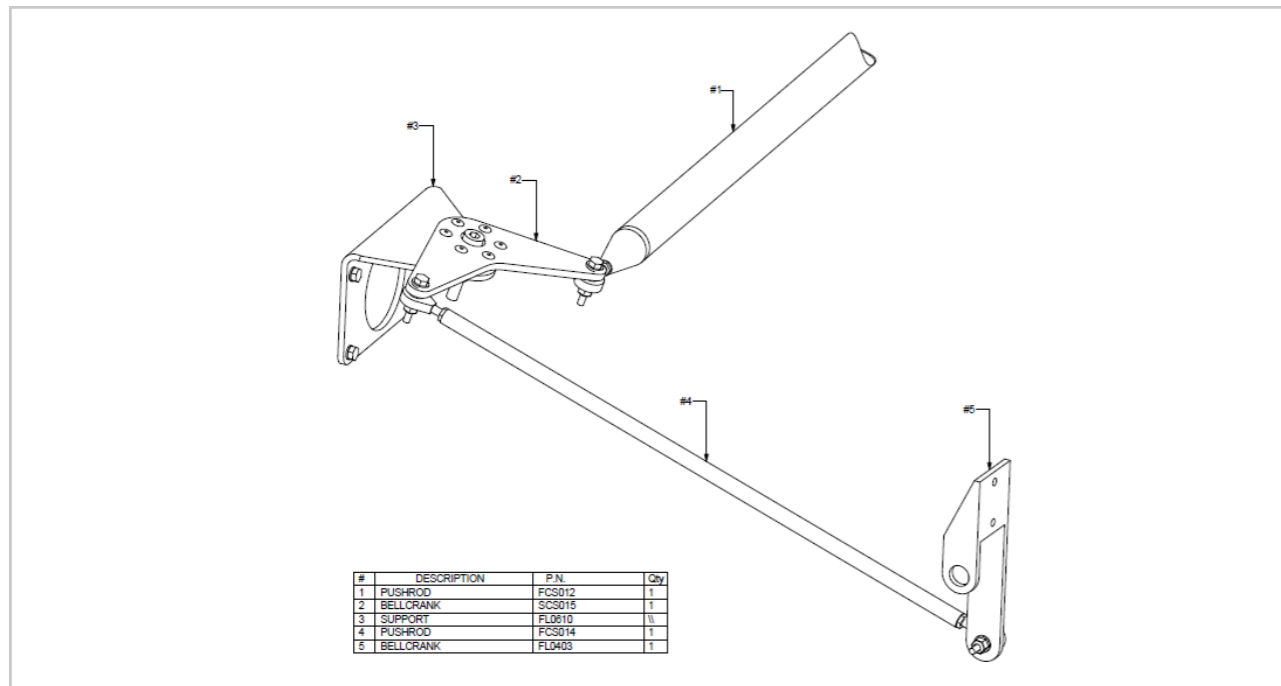

2.9. FLAPS CONTROL

Flaps control is electric-type, made of a linear actuator driven by electric switch. The control system is positioned inside the fuselage, accessible removing the trunk.

Flaps control is an electric switch with up-down positions located on the instrument panel in the cockpit, on the control panel; by means of it flaps can be adjusted in continuous movement from 0° to 35° positions.

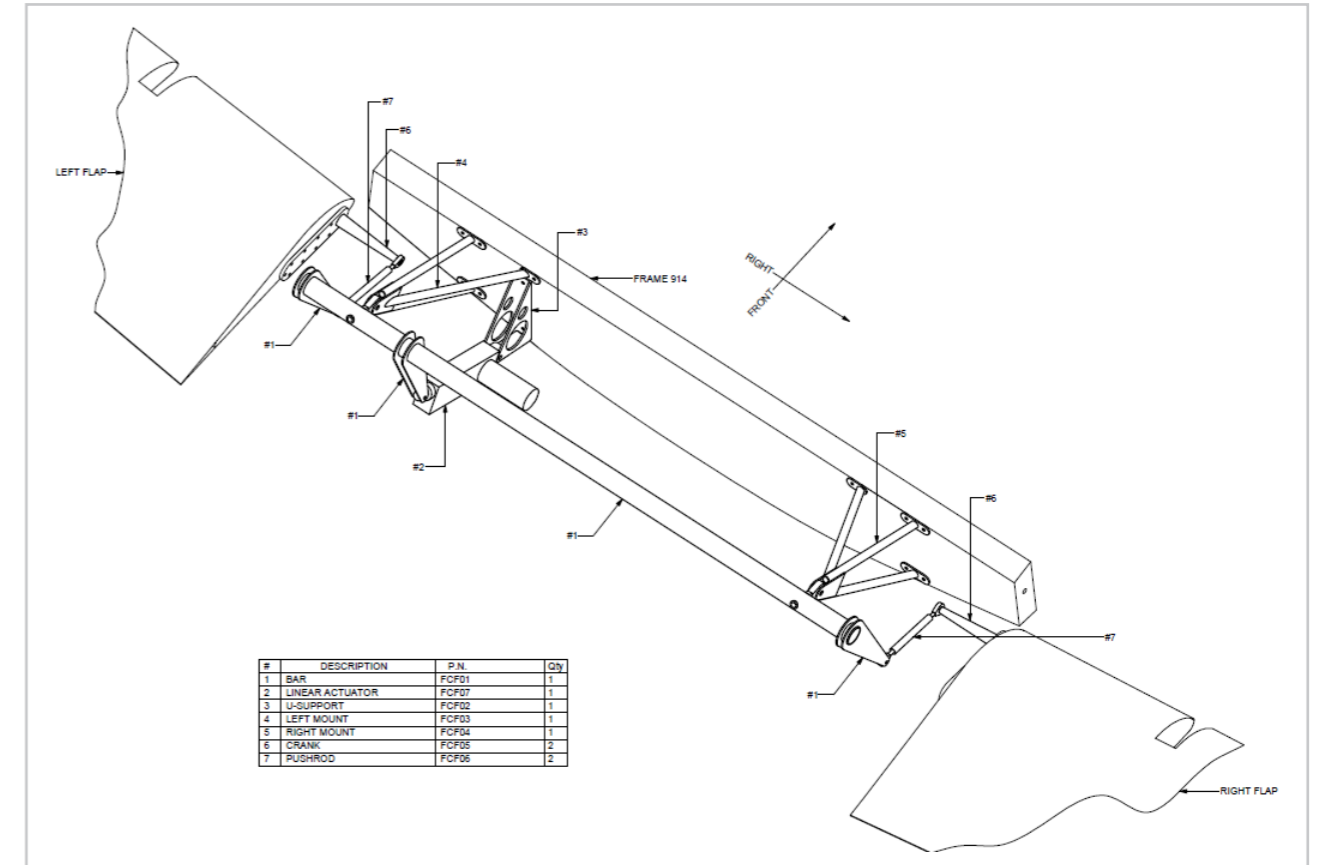

2.10. ELEVATOR CONTROL

The stabilizer is slightly in nosedive position to facilitate the aircraft nose-up, especially on take-off. The elevator travel, respect to the neutral position, is of 20° +1° upward and 15° +1° downward.

The elevator control is consisting of handle, connecting rod and quickdraw. The duralumin tube is connected to axis, by means of ball bearing. The flapping of the "pushed" or "pulled" handle is limited by control stops on the two sides of the axis.

The axis is fastened to the fuselage frame's bottom tube through two bolts; around them the control stick is rotated lengthwise.

The control-stick quickdraw is connected to the elevator one through a bar.

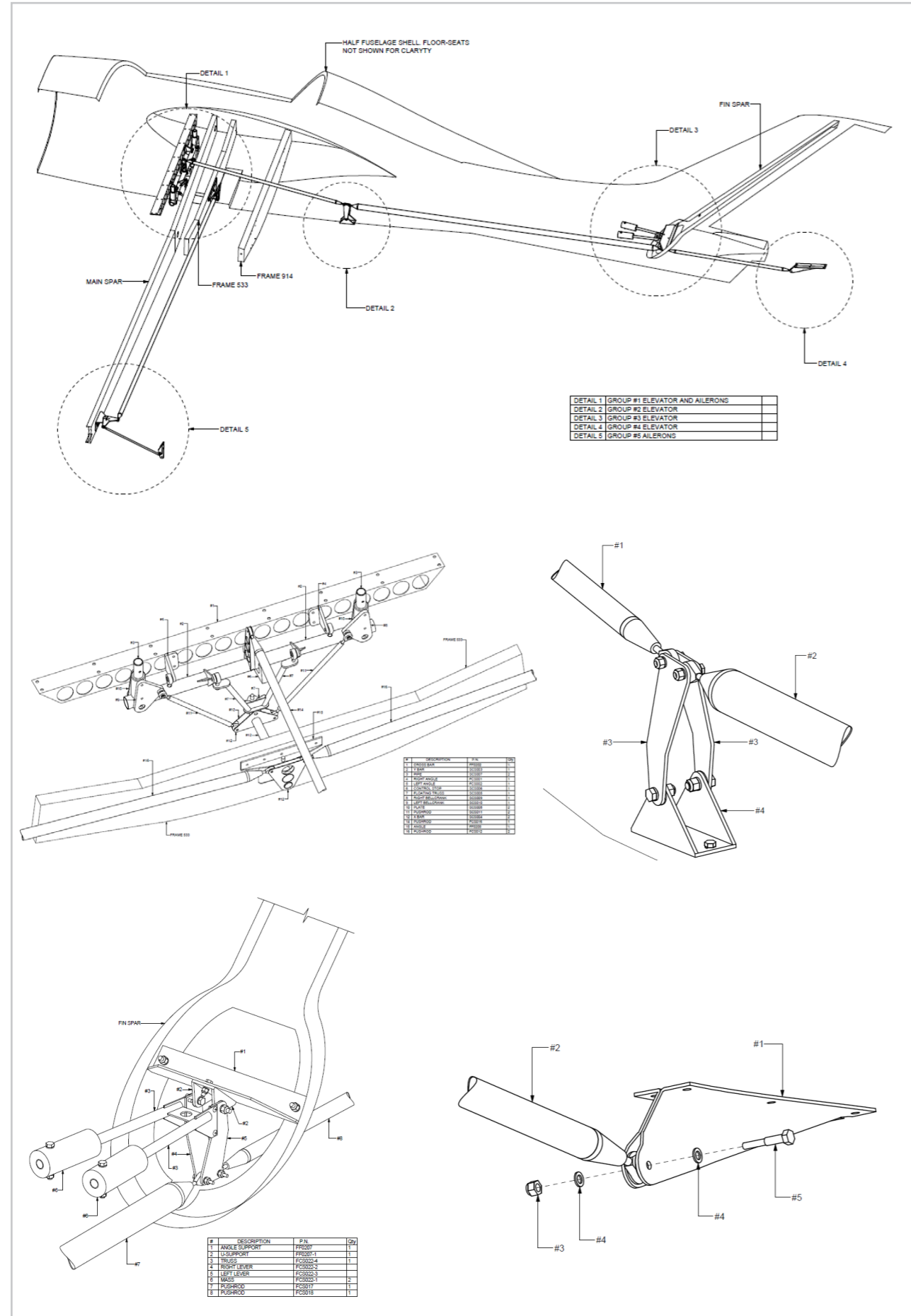

Adjustment of The Elevator Control

The control stick's neutral position in the cockpit must correspond to the elevator control's neutral position.

The rigging of the elevator's angles of steering is possible through an adjustable connecting-rod. To modify the length:

- 1 unscrew the connecting rod from the elevator's bellcrank ;
- 2 unscrew the locknut;
- 3 then screw or unscrew the adjustable head.

Check of the system is made in the following points:

- 1 open inspection hole below the fuselage to have access to stick group
- 2 remove the trunk to have access to the control quickdraws
- 3 check nuts and locking nuts of the system.

2.11. TRIM CONTROL

Trim adjusts the elevator position in a more accurate way to avoid continual corrections by the control stick in flight.

Its movement is electric controlled by a switch located inside the cockpit, on the stick grips and which transmits the movement to the actuator, positioned inside the elevator.

Adjustment of the travel is possible by the pushrod that join the actuator to the trim bellcrank.

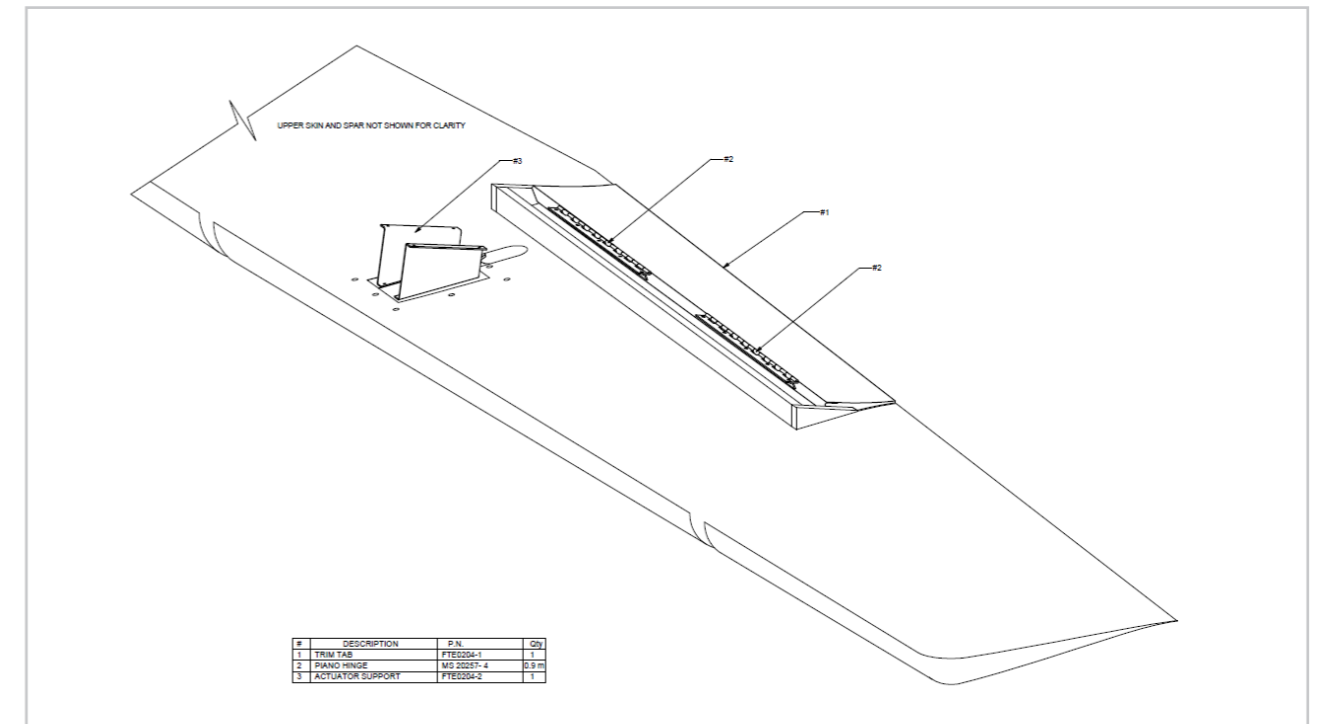

2.12. RUDDER CONTROL

Rudder control consists of pedals, connecting rods, bearings, bowed cables. The left and right pedals have independent-rotation axles. Two cables, the left one and the right one, are fixed on the eyelets welded to the pedals. The cables are fixed on their other edge to the rudder bellcrank which are installed on the rudder through a plate glued and screwed.

The control system ends with the connecting rods which link the pedals to the front undercarriage (nose wheel).

The control stops of rudder steering are put on the support of the steering bellcrank. The rudder's angle of steering on the left and on the right is of $\pm 25^\circ$.

Adjustment of The Rudder Control

The angles of steering from the neutral position are of $\pm 25^\circ \pm 2^\circ$.

As for the adjustment you must:

- 1 Put the nose wheel in neutral;
- 2 It is necessary that neutral position of the rudder pedals correspond to neutral position of nose wheel. Access to nose wheel – rudder pedals pushrods for check and adjustment are two inspection holes on the firewall.
- 3 Then check or adjust the uniball that connect Bowden cable to rudder bellcrank so also the rudder is in neutral position. The cables cross at the back part of the fuselage.
- 4 At the end, they must be tightened gradually until the rudder is straight and it doesn't move.

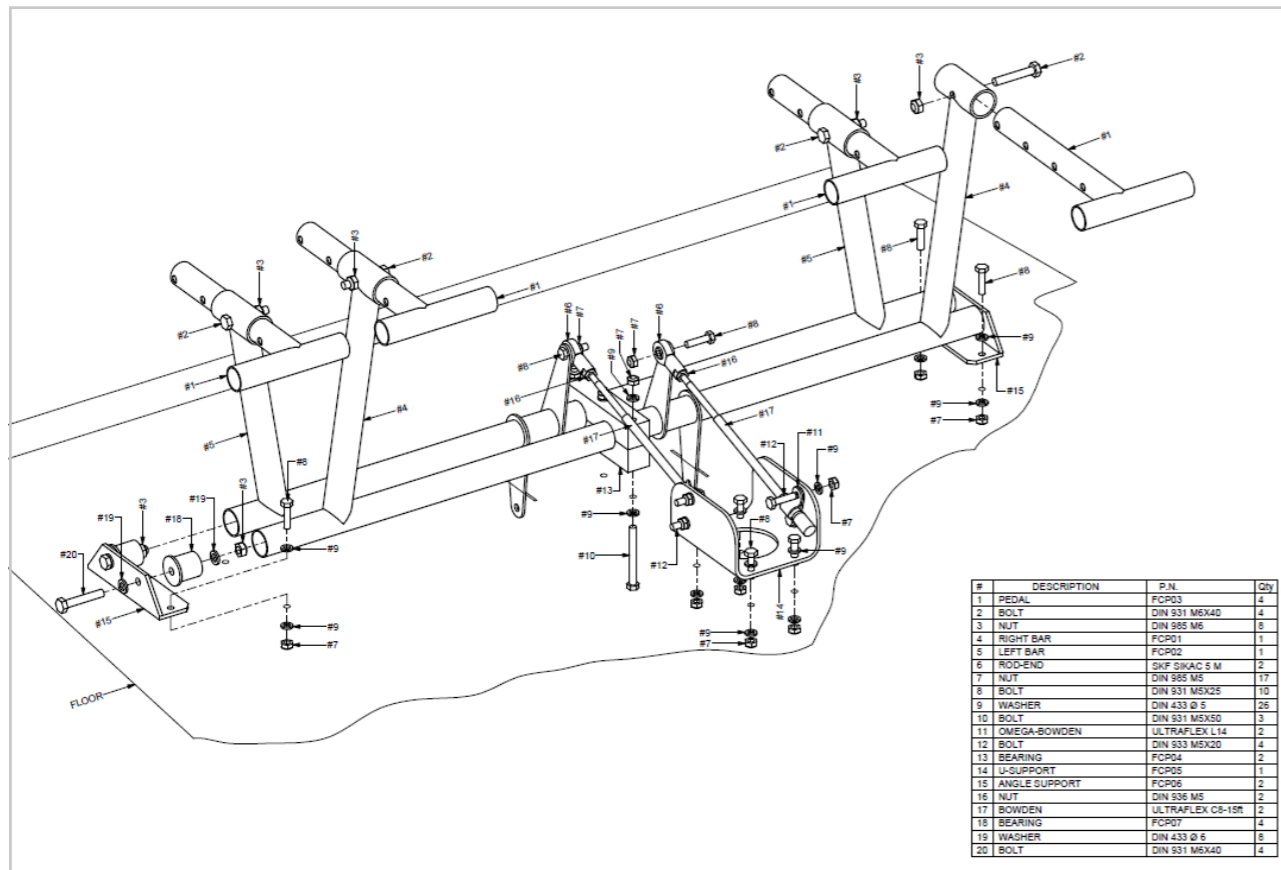

2.13. UNDERCARRIAGE

It is a fixed three-wheel undercarriage with a turning nose wheel and disc brakes on the main landing gear. Fairing are installed as optional components

The front undercarriage leg is made of steel and it is provided with shock absorber. Front undercarriage is connected to rudder pedals.

The main undercarriage legs are made of composite materials.

UNDERCARRIAGE

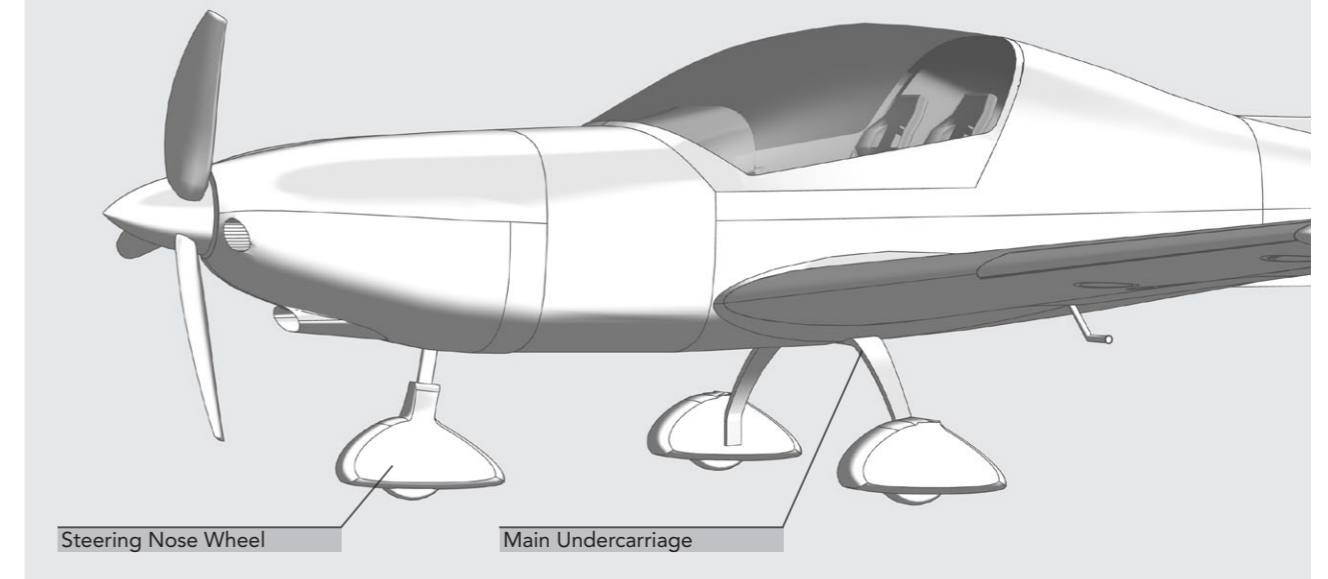

	Dymension		Pressure
Nose wheel	4.00 – 4"	8 ply	1.5 bar
Main wheel	13x5.00 - 6"	4 ply	1.8 bar

2.14. EQUIPMENT

MINIMUM CONFIGURATION

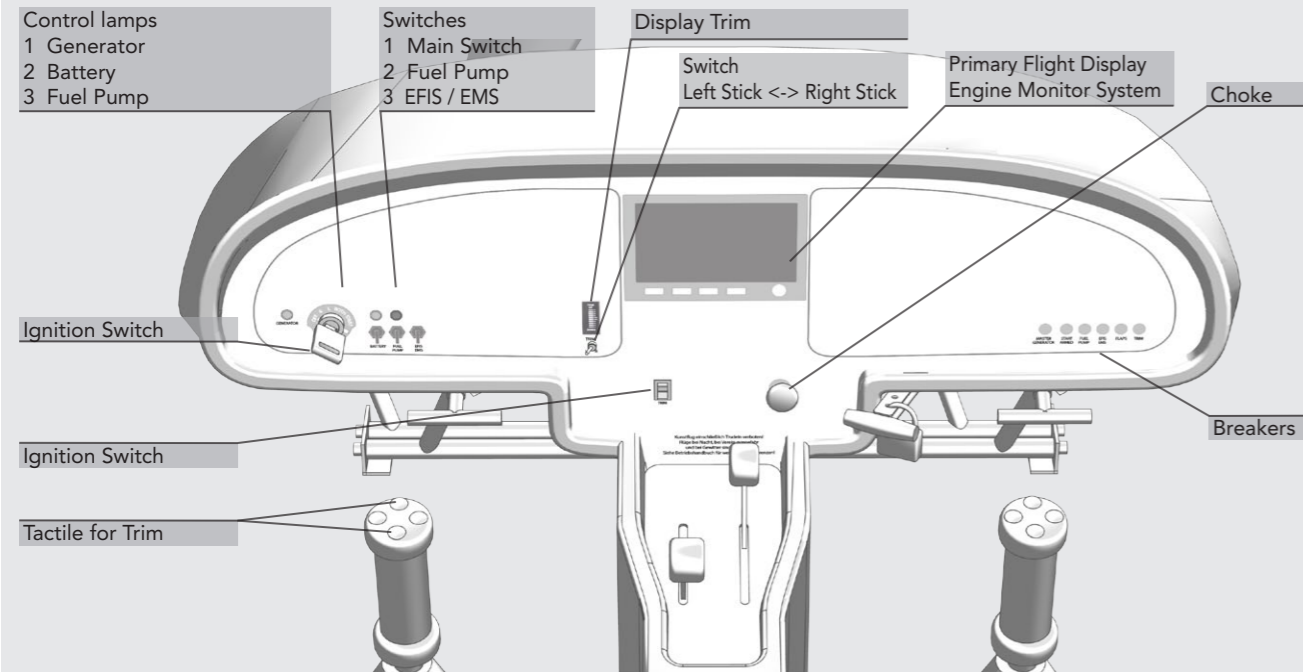

MAXIMUM CONFIGURATION

This cockpit shows the maximum configuration with analogue instruments. The equipment can be configured differently. Therefore deviate the actual features of this figure.

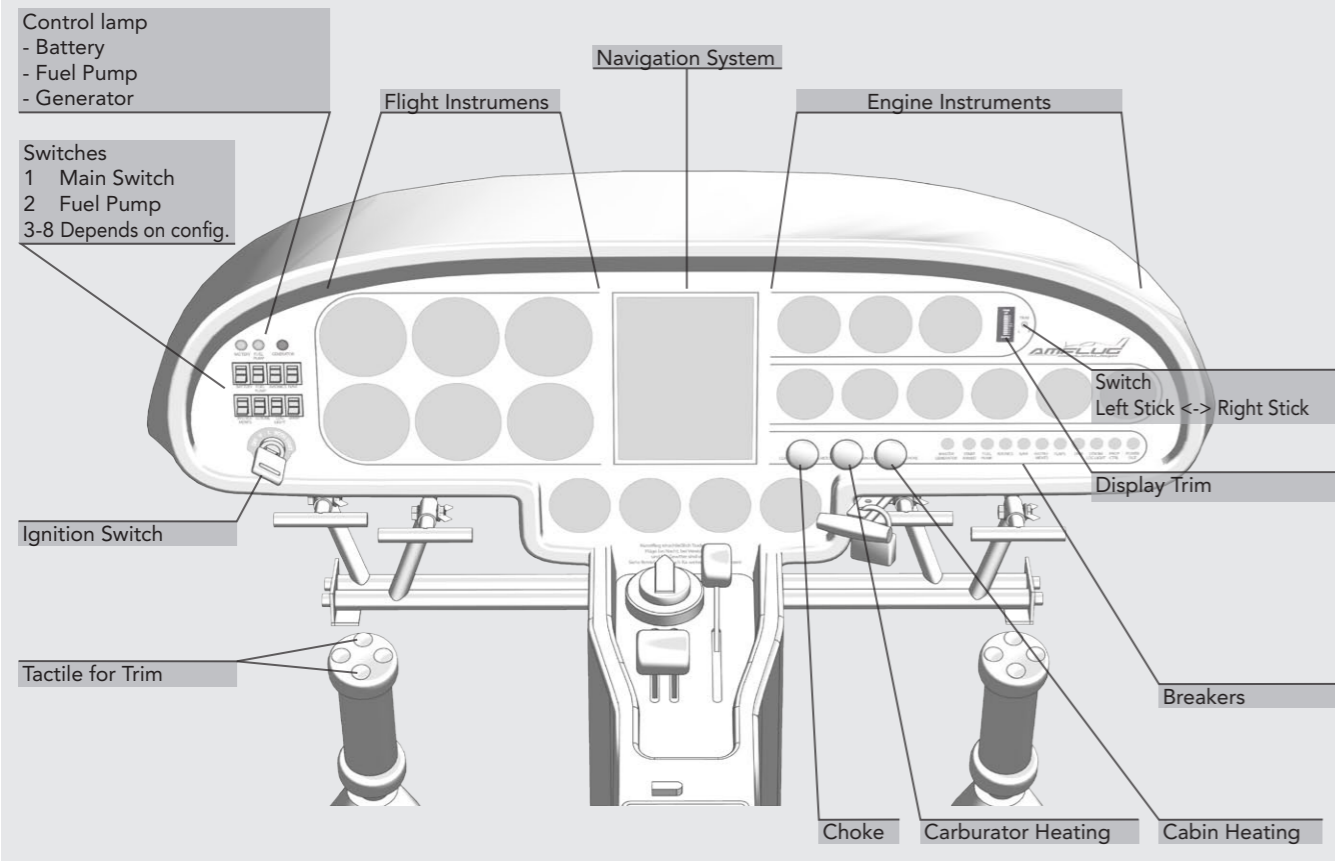

2.15. PRIMARY FLIGHT DISPLAY AND ENGINE MONITOR SYSTEM (DEPENDING CONFIGURATION)

PFD / EMS



DESCRIPTION

PFD	Artificial horizon
	Anemometer
	Altimeter
	Compass
	Variometer
	G-meter
	Turn coordinator
EMS	Fuel pressure
	Oil pressure
	Oil temperature
	2x CHT
	2x EGT
	Voltmeter
	RPM
	Hour meter
	MAP
	OAT
	Fuel quantity indicator

2.16. ELECTRICAL SYSTEM

The aircraft is equipped with a 12-volt, direct-current electrical system with grounded negative pole.

The primary source of electrical energy is provided by the engine mounted interior alternator/generator with total power of 750 W.

The internal alternator located at the rear of the engine block will charge the battery up to 13.5 VDC.

Power is supplied to the electrical and avionics circuits through a main bus bar located behind instrument panel, this bus bar is energized anytime the Main switch is ON.

Each system is protected by circuit breaker which is permanently on. If some circuit is overloaded, then the circuit breaker disconnects that circuit.

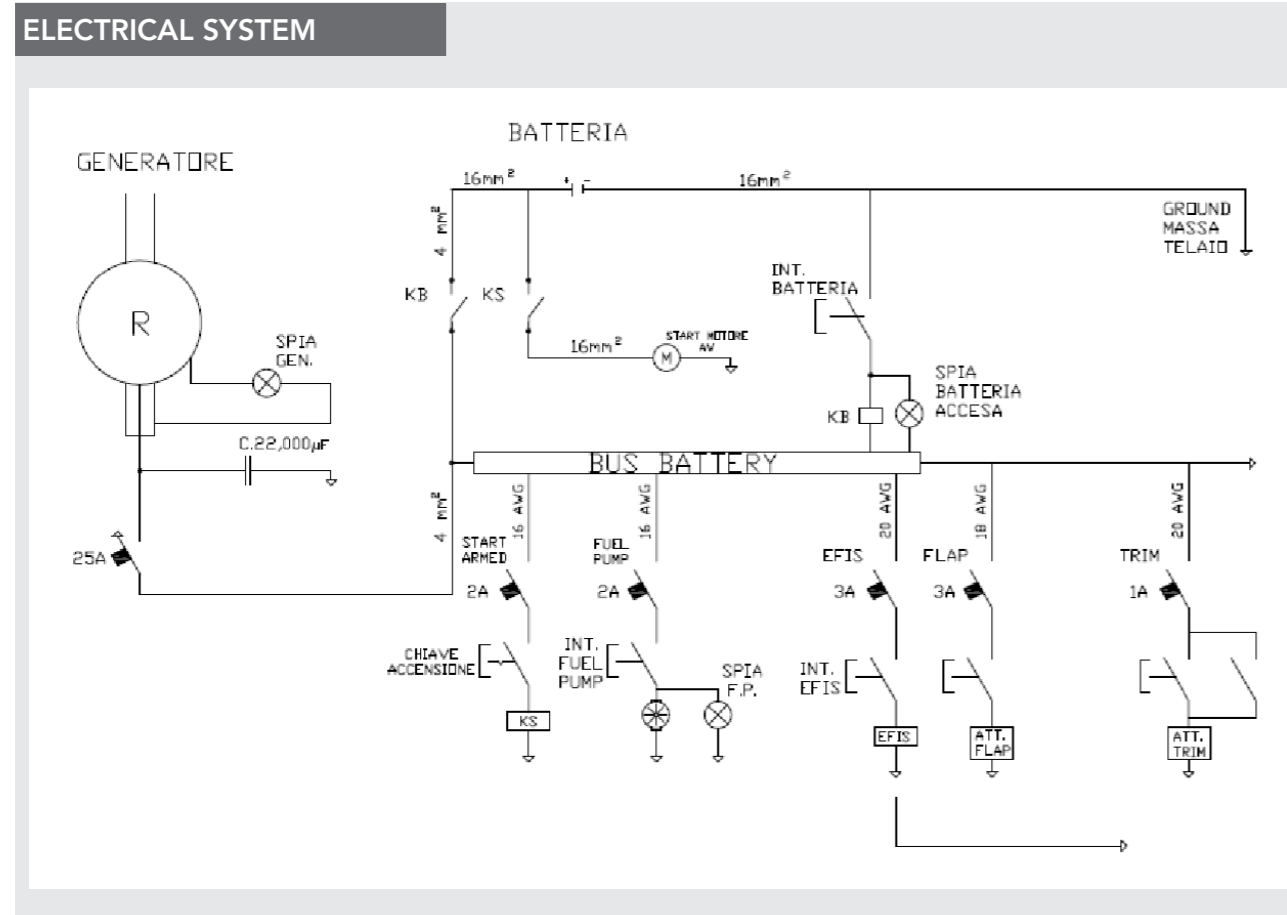

FUSES

Start Armed	2 A
Fuel Pump	2 A
EFIS	3 A
Flap	3 A
Trim	1 A

2.17. ENGINE – ROTAX 912 ULS

For engine inspection and maintenance refer to original Rotax manuals supplied with the aircraft:

- Operator's Manual for ROTAX engine Type 912 Series
- Documentation for ROTAX aircraft engines (CD – ROM)
- Service instruction fur ROTAX Type 912 und 914 (series)
- ROTAX service letter Warranty conditions for ROTAX engine types 912 and 914 (series)
- ROTAX engine Log book

Engine removal, installation and replacement can only be done by Pro.Mecc authorized service center.

ENGINE CONTROL

On the central control panel, in the middle of the cockpit there are the handgrips relative to:

- Throttle lever
- Choke push pull cable

The power levers and the choke one are fixed to a control box made of carbon fibre and they are linked to steel-sheath cables.

The cables, fastened to the fuselage structure, pass the firewall and inside engine compartment are fixed to a box that has the function to double the controls in order to reach the throttle lever and the choke lever of the two engine carburetors.

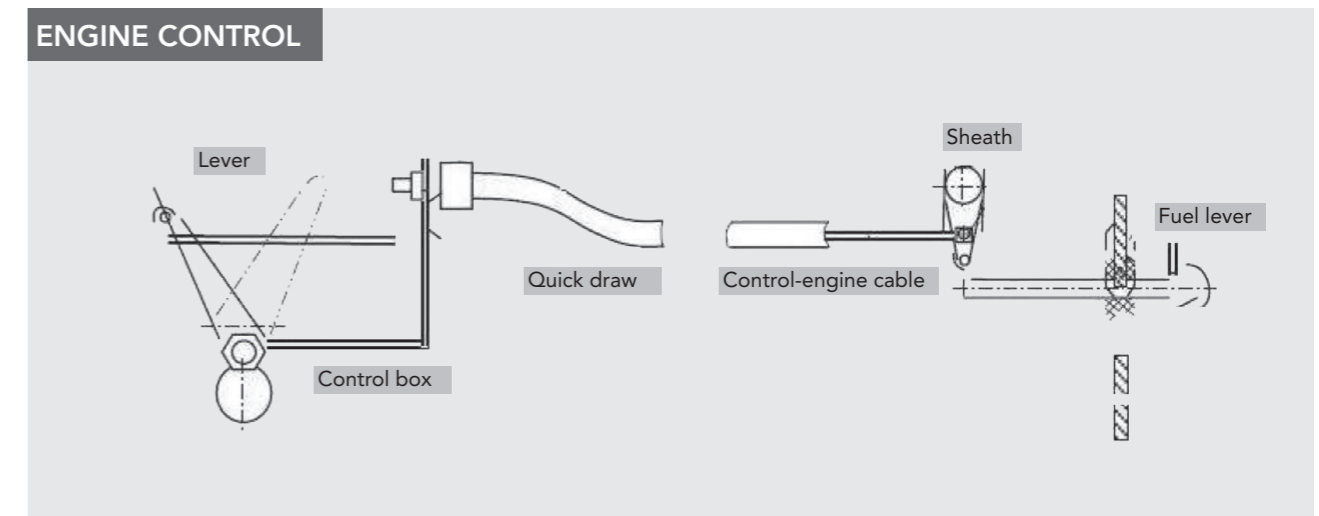

Adjustment of engine control

The engine-control lever must move with a right effort. In case of effort's weakening, in flight the lever could move ahead spontaneously and the engine's power setting would increase. In this case, adjust the engine choke lever. Loosen the M8 nut, lock it with a proper spanner and secure; consequently, the friction increases and the engine's control lever remain in a more appropriate position.

ENGINE LUBRICATION SYSTEM

The engine lubrication system limits the wear and tear of the engine elements and ensures their partial cooling and evacuate the rejects of wear and tear.

ROTAX 912 UL(S) engine is equipped with a dry sump forced system including a main oil pump with an integrated pressure regulator (1) and a oil-pressure sensor (2). The integrated oil pump is activated through the camshaft.

Through the depressurizing created by the pump (3), the engine oil is driven from the tank (4) through the oil cooler (5), through the filter (6) to the lubrication points in the engine.

The oil in excess overflowing from the lubrication points accumulates in the bottom of crankcase and it's pushed back, to the tank by blow's gas.

The oil circuit is vented by a bore on the oil tank.

The oil-temperature sensor (8) is located on the oil pump housing.

ENGINE LUBRICATION SYSTEM

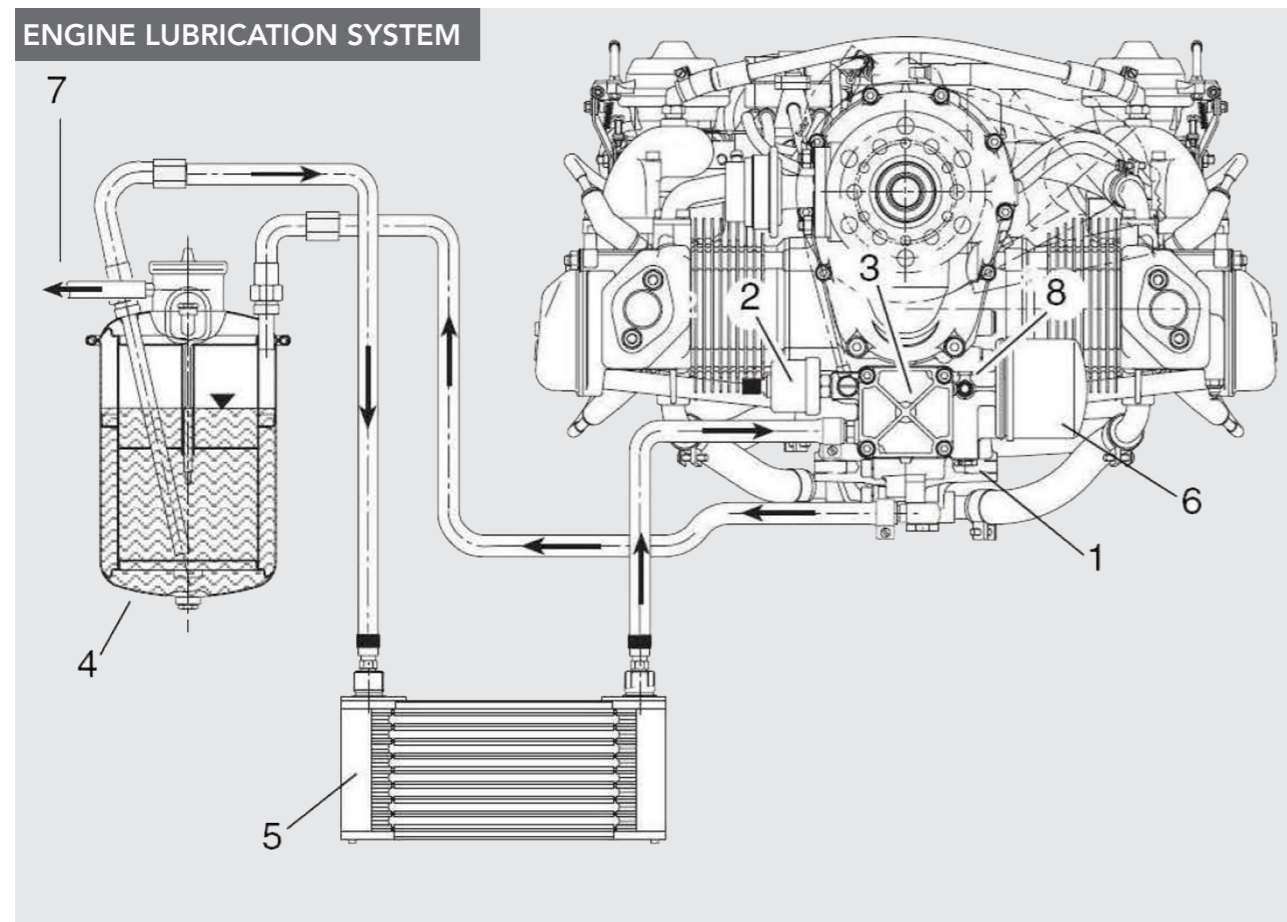

ENGINE COOLING SYSTEM

The function of ROTAX 912 UL(S) cooling system is to guarantee liquid cooling for cylinders heads and air cooling for cylinders. Cylinders heads cooling system is at closed circuit with an expansion tank.

Cooling fluid is pushed by the pump (set in motion through camshaft) from radiator to cylinders heads. From the top of cylinders heads, cooling fluid reaches the expansion tank (1). Since, usually, the radiator position (2) is lower than the engine one, the expansion tank located above the engine allows the cooling fluid to flow. Expansion tank, shut with a pressure cap (3) provided with overpressure valve and return valve, opens and cooling fluid runs through an atmospheric pressure tank to a transparent overpressure container (4). When cooling temperature begins to decrease, fluid is sucked down to cooling circuit.

Cooling fluid temperatures are measured by sensors installed on cylinders heads 2 and 3.

Temperature readings are taken by measuring the hottest point of cylinder head, according to engine installation.

COOLING SYSTEM

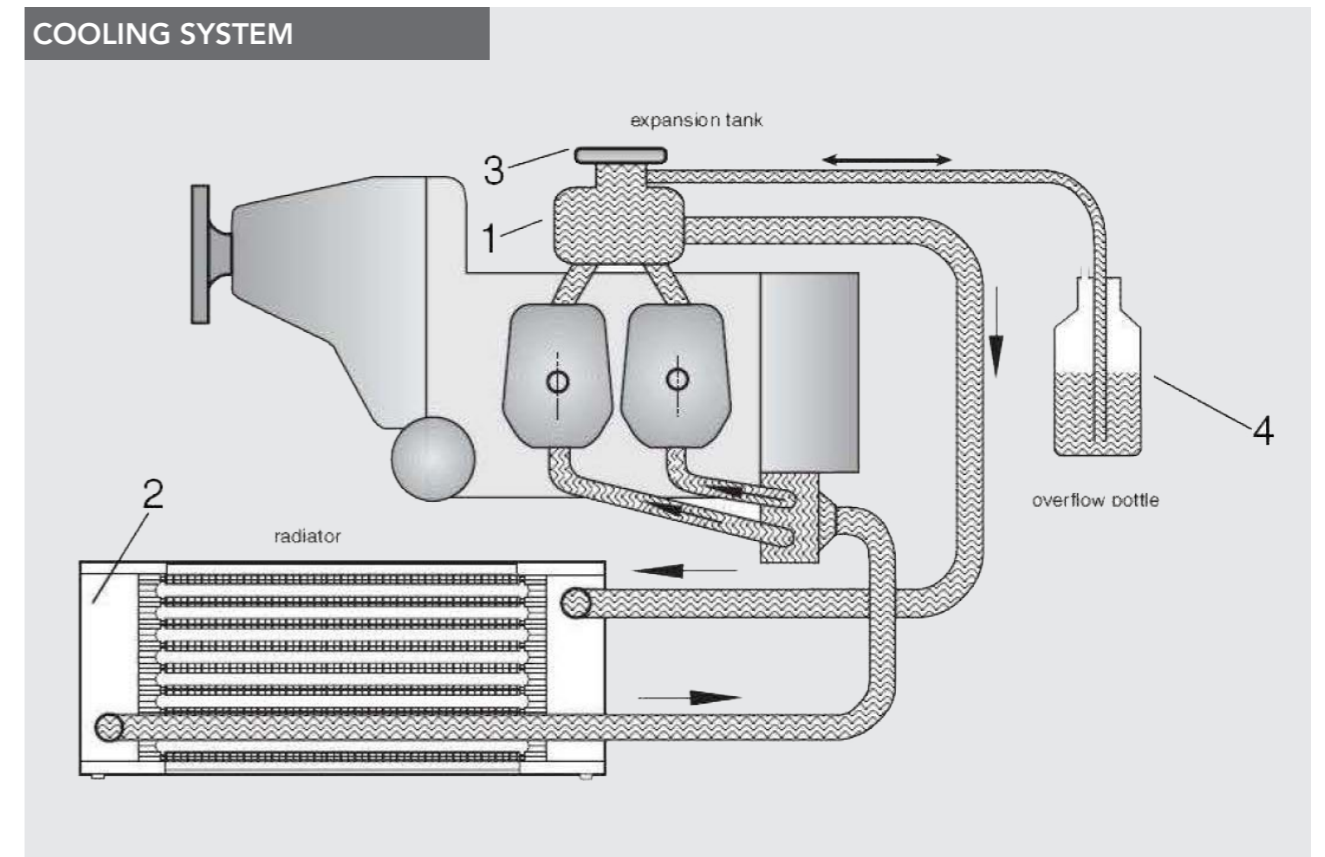

Coolant Fluid: see Engine Operator Manual.

FUEL SYSTEM

Freccia in basic version is equipped of a fuel tank installed inside right wing, having capacity of 50 liters. The drenable quantity of fuel is 48.5 liters.

It is available as option the second fuel tank that can be installed on the left wing.

System schema is represented below.

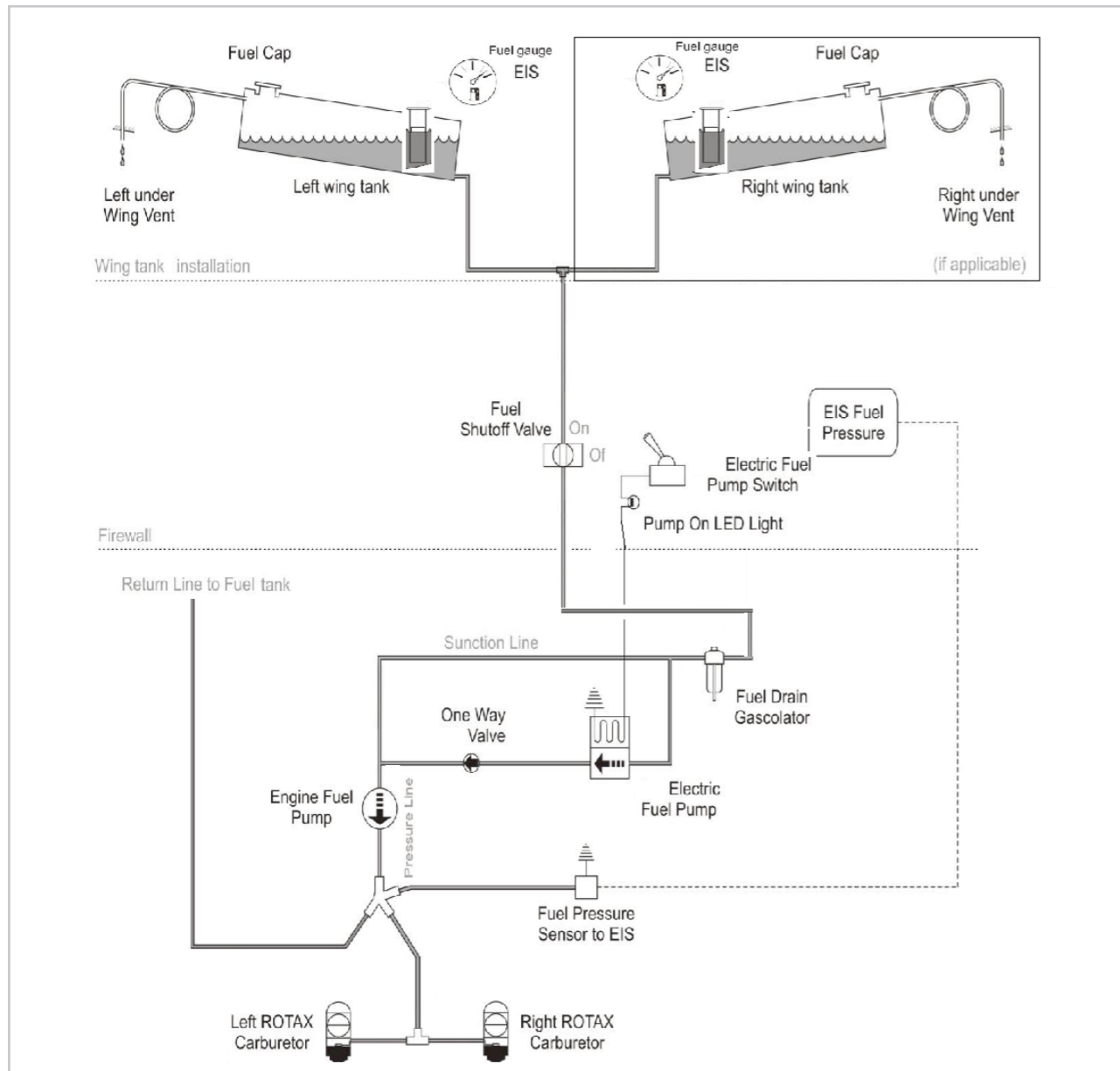

Gascolator inspection/cleaning

- 1 Remove upper cowling and bottom cowling.
- 2 Make sure the Fuel Selector Valve is in the off position.
- 3 Drain the Fuel gascolator by the draining vent on the fuel gascolator tank. Remove all fuel from Fuel gascolator tank.
- 4 Remove Fuel filter tank from the Fuel gascolator
- 5 Clean Fuel gascolator fuel strainer and sediment bowl. Inspect the Fuel gascolator sealing for condition, replace it if damaged.
- 6 Install back Fuel filter tank from the Fuel gascolator. The rest of the Fuel filter tank installation process goes in reverse to the Fuel filter tank removing process.
- 7 Move the Fuel Selector Valve to the Right tank position ON. Inspect Fuel Gascolator for leakage.
- 8 Install back the Upper cowling and Bottom cowling.

2.18. PITOT – STATIC PRESSURE SYSTEM

The pitot-static tube is located under the leading edge of the right wing and consists of a air duct. Total system pressure is sensed through the hole in the pitot-tube face and static pressure is sensed through the holes on both sides of the rear part of fuselage.

Pressure distribution to individual instruments is received by means of flexible plastic hoses. The tube supplies dynamic ram air pressure to the airspeed indicator, and the static ports supply outside atmospheric pressure to the airspeed indicator, altimeter, and vertical speed indicator. If installed, the altitude hold portion of the autopilot or mode C transponder is also connected to the pitot system.

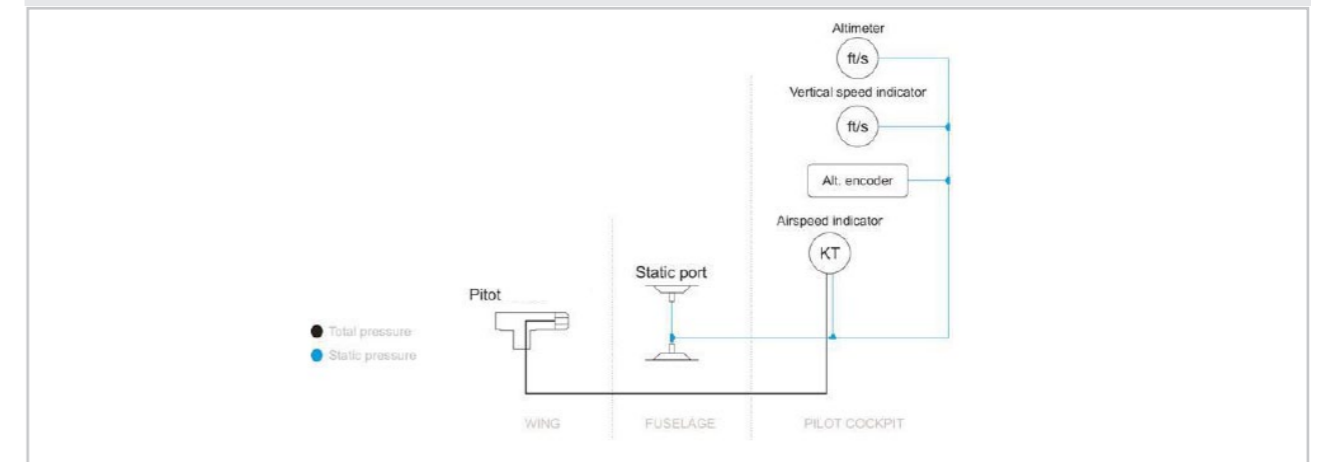
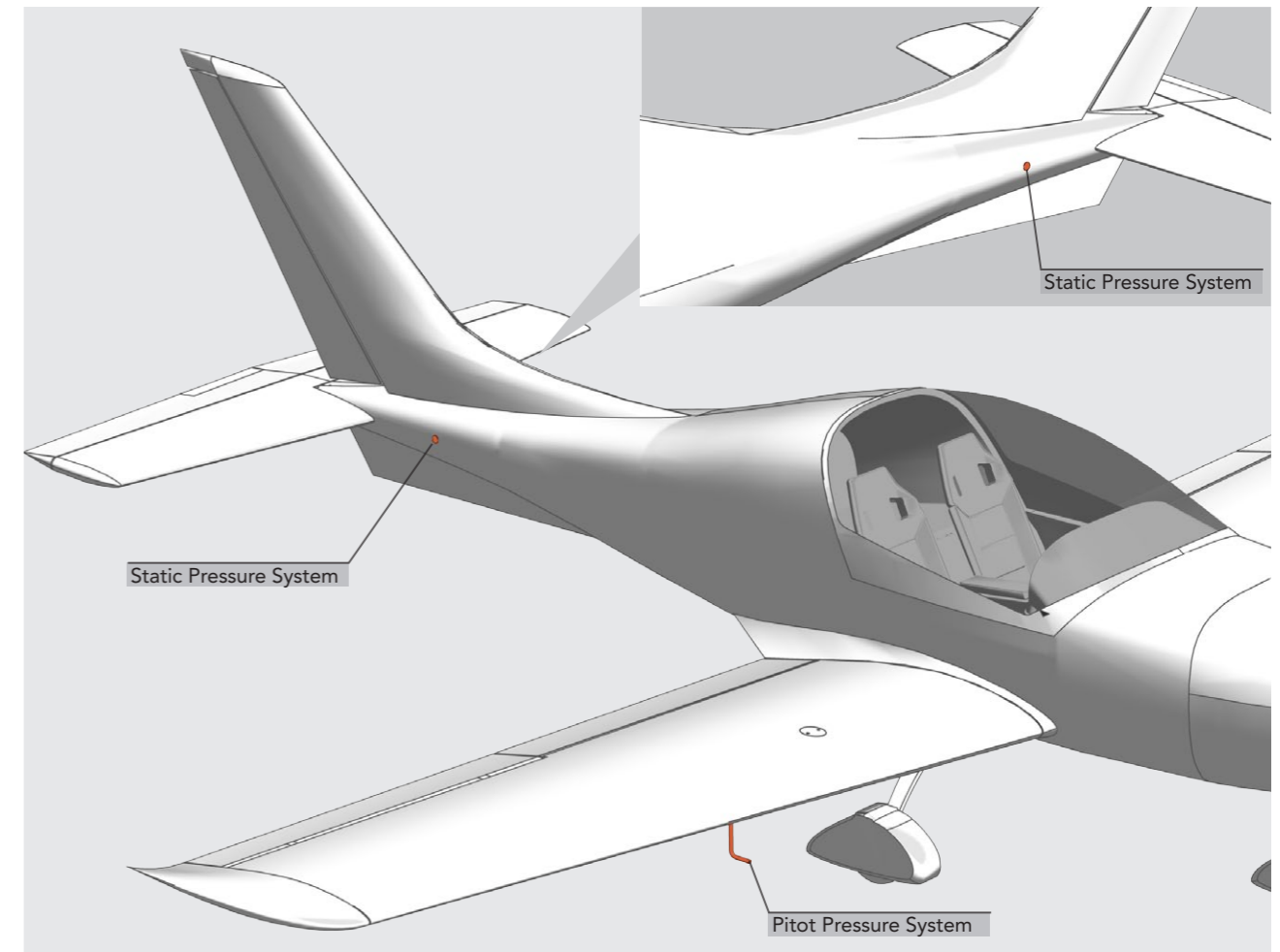

2.19. PROPELLER

Manufacturer: DUC HELICES
Model: 3-blade Inconel SWIRL clockwise
Diameter: 1730 mm

For propeller inspection and maintenance refer to original propeller manufacturer's Manuals.

Propeller removal, installation and replacement can only be done by Pro.Mecc or propeller manufacturer authorized service center.

2.20. BRAKE SYSTEM

The braking system consists of one brake lever positioned in the middle of the control panel, that by the means of a brake pump operates on the two brake systems on the rear wheel.

The left and right brake share a common fluid reservoir installed on the top right of the firewall. Care must be taken to avoid applying brake pressure when using rudder on the ground.

The parking brake control valve is mounted in the middle of the two seats, rear to the central control panel. The parking brake is OFF if the control lever is rotated vertically upwards, and it is ON if the control lever is rotated horizontally to the sense of flight.

Schematic of the system is represented below.

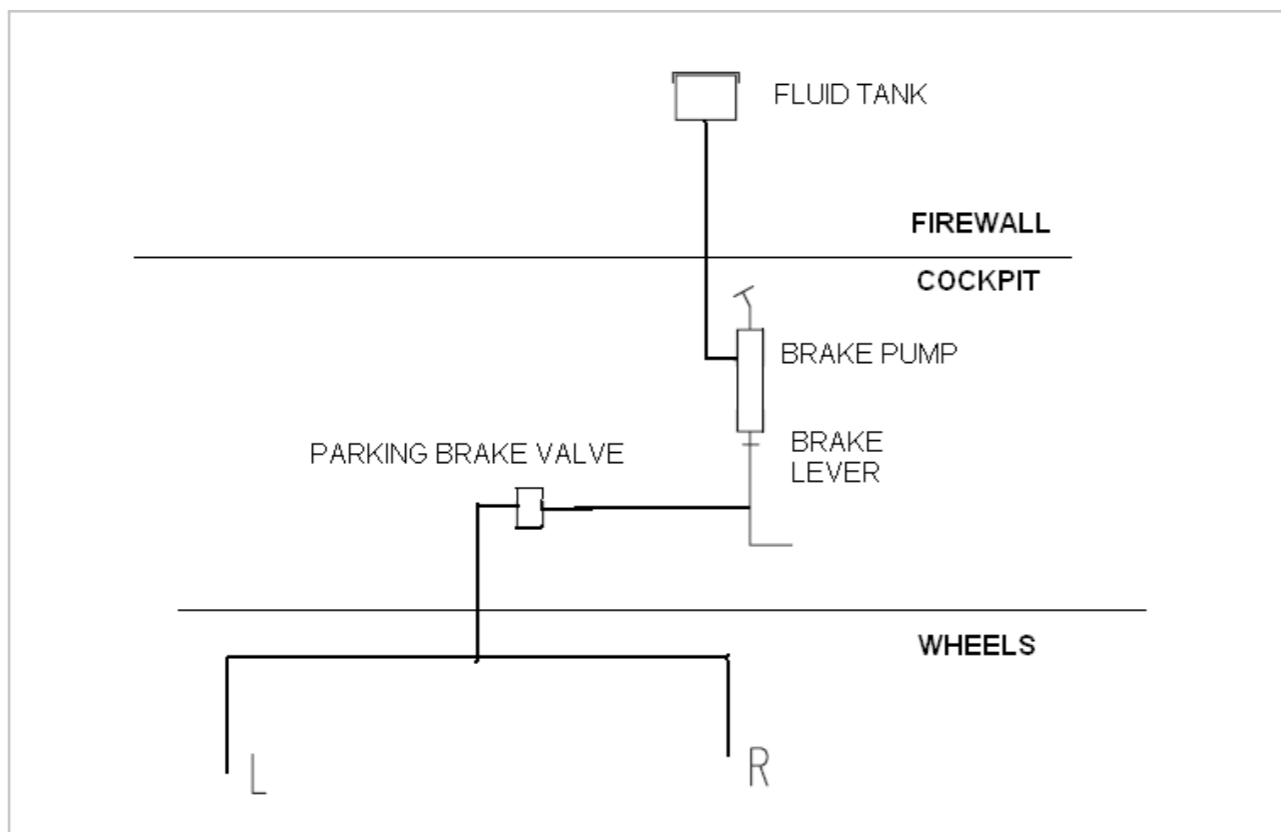

Fluid replacement: BRAKE FLUID DOT 4.

3. INSPECTIONS

This section contains some requirements concerning inspections and basic maintenance, which are to be observed in order to maintain the performance and reliability of a new airplane. It also contains procedures for the correct handling of the airplane and servicing, recommended by the airplane manufacturer.

It is reasonable to proceed according to a prescheduled scheme of lubrication and maintenance, appropriate to the operating conditions and climate.

3.1. SCHEDULED AIRPLANE INSPECTIONS

The scope and the intervals of the inspection schedule are defined.

Tasks to be carried out in relation to scheduled inspections of engine, propeller, rescue system and equipment, are defined in the respective applicable manuals or operating and maintenance instructions.

The owner and operator are responsible to ensure that all handling, servicing and maintenance are only carried out by qualified personnel.

The table below indicates recommended maintenance periods.

Table legend:

C	Check-up - visual only, check for free play and whether everything is in position DO IT YOURSELF
CL	Cleaning DO IT YOURSELF
LO	Lubricating, oiling - lubricate all designated parts and spots using proper lubricant DO IT YOURSELF
R	Replacement - replace designated parts regardless of state and condition. You are encouraged to DO undemanding replacements YOURSELF, otherwise have replacements done by AUTHORISED SERVICE PERSONNEL
SC	Special check-up - measuring, verifying tolerances and functionality DONE BY AUTHORISED SERVICE PERSONNEL ONLY
O	Overhaul

	Daily	first 5 hours	25 hours	100 hours	200 hours	500 hours	1000 hours	10 000 hours
CHECK LIST FROM ENGINE'S MANUFACTURER MANUAL	C							
CHECK LIST FROM PROPELLER MANUFACTURER MANUAL	C							
WING AND TAIL SURFACES						SC	SC	O
surface and structure condition	C	C	C	C	SC			
deflection without free play	C				SC			
bearings - moving parts' bushing	C		LO	LO	SC			
Lights (if installed)	C							
self-adhesive sealing tape	C							
horizontal tail mount	C	C	C	C	SC			
drain holes	C			CL				
FUSELAGE						SC	SC	O
surface and structure condition	C	C	C	C	SC		SC	
elevator control tube bearing	C			LO	SC			
undercarriage struts attaching points	C	C	C	SC	SC			
doors, hinges	C			LO	SC			
rudder control wires and hinges	C			LO	SC			
CABIN						SC	SC	O
control levers, instrument panel, seats	C			C				
control levers' free play	C	C	C	C	SC			
instruments and pitot-static	C	check yearly						
glass surface: clean, attached	C							
safety harnesses and attach. points	C			C				
parachute rescue system activation handle	C	see manufacturer's manual						
wing connectors: fuel, electrical	C	C	C	C	SC			
bolts and spar pins	C	C	C	C	SC			
wing main bushing, control connectors	C	C	C	C	SC			
UNDERCARRIAGE						SC	SC	O
tires	C	replace on condition or every 5 years						
main strut, tail/nose wheels strut condition	C	C	C	C	SC			
wheel axis and wheels				C	SC			
hyd. brake lines	C			C	SC		R	
brake fluid	C			C	SC	R(500 hrs or 5 years)		
brake discs				C	SC	(R on condition)		
wheel bearing				C	SC	R		
wheel fairings	C			C	C			

CONTROLS (LO every 100 hrs or yearly)								SC	SC	R
general free play	C				C	SC				
control stick	C				LO	SC				
rudder pedals (damage, centered, paral.)	C				C	SC				
rudder wire rope	C				C	SC				
bolts, visible bearings (tail, fuselage)	C				C	SC				
difficult-to-reach bearings (wings, under cabin floor)					LO	SC	LO+SC			
aileron, elevator and rudder hinges	C				LO	SC				
flap handle	C				C	SC				
elevator trim	C				C	SC				
ENGINE										
In addition to Rotax manual:										
four-strokes engines (overhaul every 2000 hours)										
engine cover screws	C	C			C					
engine mount	C	C			SC					
engine mount dumpers and other rubber parts		C			SC	R every 500 hrs or 5 years				
air filters	C	C			CL	SC				
electric terminals, joints and connectors, hoses, radiator mount	C	C			SC					
exhaust muffler	C	C			SC	SC				
exhaust pipe springs and fire protection	C	C			SC	R				
throttle, choke, propeller wire drive					SC	R				
ENGINE CONTROL										O
choke and throttle lever wire ropes	C				C+LO	SC	R			
levers	C				C	SC				
PROPELLER AND SPINNER										
surface condition	C									
fastening bolts				C	C	R				
propeller pitch	C					SC				
propeller balance	C						SC			
FUEL SYSTEM										O every 500 hrs or 5 years
general leakage	C				SC	SC	SC			
water inside gascolator	C		SC	SC	SC	SC				
dirt and gascolator filter	C	CL	CL	CL	CL	R				
wing fuel tank caps	C									
fuel tank caps o-ring							R every 500 hrs or 5 years			
fuel valves and leakage	C									

ELECTRICAL WIRING						SC	SC	R
battery	C			C	SC			
battery fluids				C	SC			
instrument panel wires and connectors				C	SC			
NAV, AC and LDG lights	C							
fuses	C							
OIL AND WATER LINES	O evry 500 hrs or 5 years							
oil and cooling fluids level	C							
oil and cooling fluids leakage	C							
four-stroke engines oil (and engine filters) first 25 hours	refer to engine manual							
cooling fluid (level)	refer to engine manual							
hoses	C			SC	SC	R		
radiators	C							
water radiator pressure caps	refer to engine manual							
PITOT-STATIC LINING						SC	SC	O
instrument to pitot tube lining				C	C			
instrument setting	C							
pitot tube condition (clean, firmly attached)	C			C	C			
whole pitot-static lining				C	C			

3.2. INSPECTION AFTER FIRST 25 HOURS

Note: the inspections on engine after the first 25 hours of flight must be carried out in accordance with the engine's operating manual, as well as the following hours.

- 1 Verify the correspondence of the final positions of the engine's control lever and the choke's control with the carburettors' levers.
- 2 Remove the wheels' fairings, lift the wheel and check it as regards the presence of axial play, check the condition of the brakes' discs, of brakes' brackets. Check the tyres' pressure.
- 3 Check the correspondence of the neutral positions of rudders, of flaps and of ailerons with the neutral positions of controls and of control stick. Check how the control levers work when smoothly.

3.3. INSPECTION AFTER 100 HOURS OF FLIGHT (AT LEAST ONCE A YEAR)

Note: the inspections on engine after 100 hours of flight must be carried out in accordance with the engine's operating manual, as well as the following hours.

In addition to the inspections after the first 25 hours of flight

- 1 Make sure that the battery is disconnected and that the supply-system valve is locked.
- 2 Check the lower part of wings and the engine cover, by making sure of the absence of petrol leaks from the fuel tanks, and of oil leaks from the lubrication system.
- 3 Check the fixing of propeller spinner.
- 4 Remove the covers.
- 5 Check the engine, by making sure of the absence of fluids' leaks from the joining of the tubes and of the engine, as well as the fixing of the elements.
- 6 Make the engine turn and make sure of the good working of all cylinders. In case of cylinders which are not so much warmed-up or overheated, identify the reason of this event.
- 7 Clean the cover, the engine, the propeller, the elements, the tubes, the cables, the filters of the radiator and of the cooler from the oil remains.
- 8 Clean the aircraft covering and the undercarriage from dirt and dust. Tidy up the inside of the cockpit.
- 9 Check the fuel and oil reserves in the tanks and weigh up their respective consumptions.
- 10 The check-up steps is the same as the pre-flight check-up in the Flight Manual.
- 11 Check the conditions of the undercarriage's axes and the mounting tools on the fuselage frame. Check that there aren't any cracks or deteriorations at the welding spots.
- 12 Check the wheels, verify the condition of the rims about the presence of cracks or deformations. Make sure of the good fastening of the wheels' fixing nuts. Check the tyres, verify if there's an irregular consumption.
- 13 The tyres must be replaced in the case of these defects: Anomalous inflation in a part of the tyre
- 14 Wear of the covering throughout, to the chord
- 15 Cuts and tears on the covering for more than 30 mm
- 16 Verify if the tyres aren't turned compared to the rims.
- 17 Verify the tyres' pressure: Front 1,6 bar, Maingear 1,8 bar).
- 18 Check the tubes of braking circuit by making sure of the absence of brake fluid. Make sure of the absence of cracks and of deteriorations of the wheels' fairings.
- 19 Check the wing relatively to the absence of cracks and deformations. Check the wing, flap, aileron's covering about the paint's deterioration.
- 20 In case of cracks or slivers of the lacquered varnish it's necessary to renovate through a second coat.

- 21 Check by a protractor the rudder surfaces' angles of deviation. If these deviations are more important than their tolerances, adjust them.
- 22 Remove the cover's top, check the fuel circuit's tubes and the valves about the absence of fuel leaks.
- 23 Check the fixings of the battery box, tighten the fixing bolts if need be.
- 24 Check the attaches of the oil tank, tighten the fixing bolts if need be.
- 25 Remove the propeller cone, check the propeller's attachments.
- 26 Check the attachments of the tubes and of propeller-engine installation's electrical cables. If necessary, do the attachments again.
- 27 Check the fuel filter. In case of the presence of anomalous particles in the filter, it must be replaced and the tank must be cleaned.
- 28 Check the undercarriage's attachment fittings about the movement, the axle's wear and the undercarriage's elements.
- 29 Check the covers' locking, lubricate them.
- 30 Open the inspection panels and check the cables' attachment fittings, check all the control cables' channelling. Possible pulleys must spin easily, without any noises, they mustn't have any traces of wear.
- 31 Check the fuselage shell's attachment fittings.
- 32 Verify the electrolyte's voltage and its density in the battery.
- 33 Remove the aft undercarriage's wheels, check and clean the wheels' bearings, grease. Check the wheels' axle shafts about the presence of breaks and wear.
- 34 Remove the undercarriage's nose wheel, check and clean its bearings, grease, settle the wheel. Change the grease in all the joints and in all the control planes.
- 35 Check the tension of control cables.
- 36 Check the actuating rods, their attachment fittings to the quick draws, check the bolts' tightening.

3.4. LUBRICATION INSTRUCTION

UNIT	AREA OF LUBRICATION	25 H	100 H	LUBRICANT
1	Engine			
	Throttle control cable into engine compartment	X	X	Light oil
	Choke control cable into the engine compartment	X	X	Light oil
2	Nose gear			
	Nose gear leg and bearing of the link to rudder pedals	X	X	Lubrication grease
3	Main gear			
	Axle bearings	X	X	Lubrication grease
4	Ailerons			
	Hinges	X	X	Lubrication grease
	Rod end bearing of the control system	X	X	Lubrication grease
5	Flaps			
	Hinges	X	X	Lubrication grease
	Rod end bearing of the control system	X	X	Lubrication grease
	Actuator hinges	X	X	Lubrication grease
6	Tail			
	Rod end bearing of the elevator control system	X	X	Lubrication grease
	Rudder hinges and bearing	X	X	Lubrication grease
	Rudder Bowden cable	X	X	Lubrication grease
	Stabilizer – Elevator hinges	X	X	Lubrication grease
	Hinges and movable parts of trim	X	X	Lubrication grease
7	Rudder pedals			
	All moving parts in cockpit area	X	X	Lubrication grease

LUBRICATION OVERVIEW

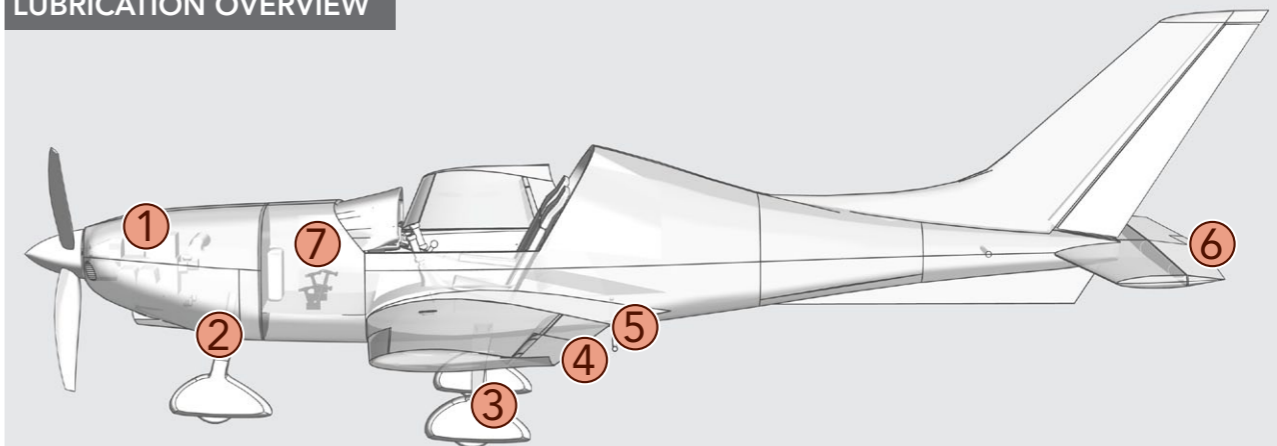

4. GROUND HANDLING

The dimensions of the standard airplane are given in the airplane drawings. This allows the size of the area required for the airplane in a hangar or for parking to be defined.

 Note: the size of the required area is to be increased respectively, to provide space for supplementary equipment such as antennas of radio equipment (or other equipment installed according to the operators options).

4.1. RELOCATING THE AIRPLANE ON GROUND

If using the towing bar on a level surface, one person is able to move the airplane. The tow bar is to be fixed to the nose wheel by means of two lugs. If the ground is not even and there are difficulties in moving the airplane, two people may manage the relocation, balancing the plane on the main wheels. One person should guide the wingtip and the other should control the movement with the tow bar.

 Do not push or pull the airplane by control surfaces and fairings. Push not on the wings, except the position in following illustration

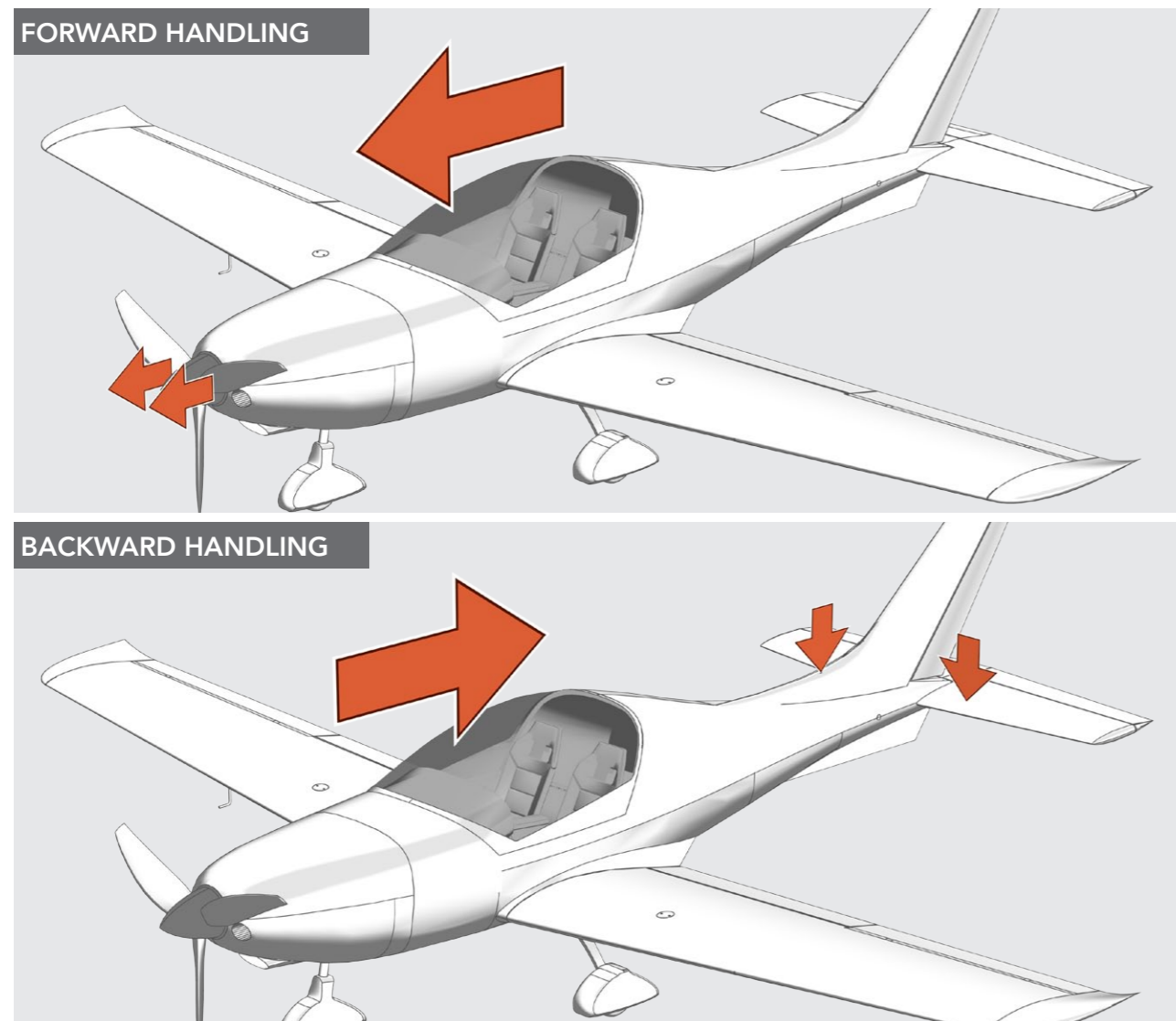

4.2. PARKING

- 1 1. Position the airplane pointing into wind.
- 2 2. Apply chocks to the main wheels.
- 3 3. Secure the control sticks with the seat belts (or tow bar gust lock).
- 4 4. Lock the cockpit canopy and apply a canvas cover, if available.

4.3. TYING DOWN

If available, lugs for the tie-down for roping the airplane.

When tying down, the following should be observed:

- 1 1. It is recommended to have the airplane pointed into wind.
- 2 2. Put chocks in front of the main wheels.
- 3 3. Apply locks to the ailerons, rudder and elevator, or fasten the control sticks with safety belts.
- 4 4. Put the ropes through the specified lugs and attach the ropes to the ground anchors. There should only be slight tension on the tie-downs to prevent sagging.
- 5 5. Apply the cover to the pitot and static pressure sensors.
- 6 6. Lock the canopy and put on the cover.
- 7 7. Position the propeller horizontally

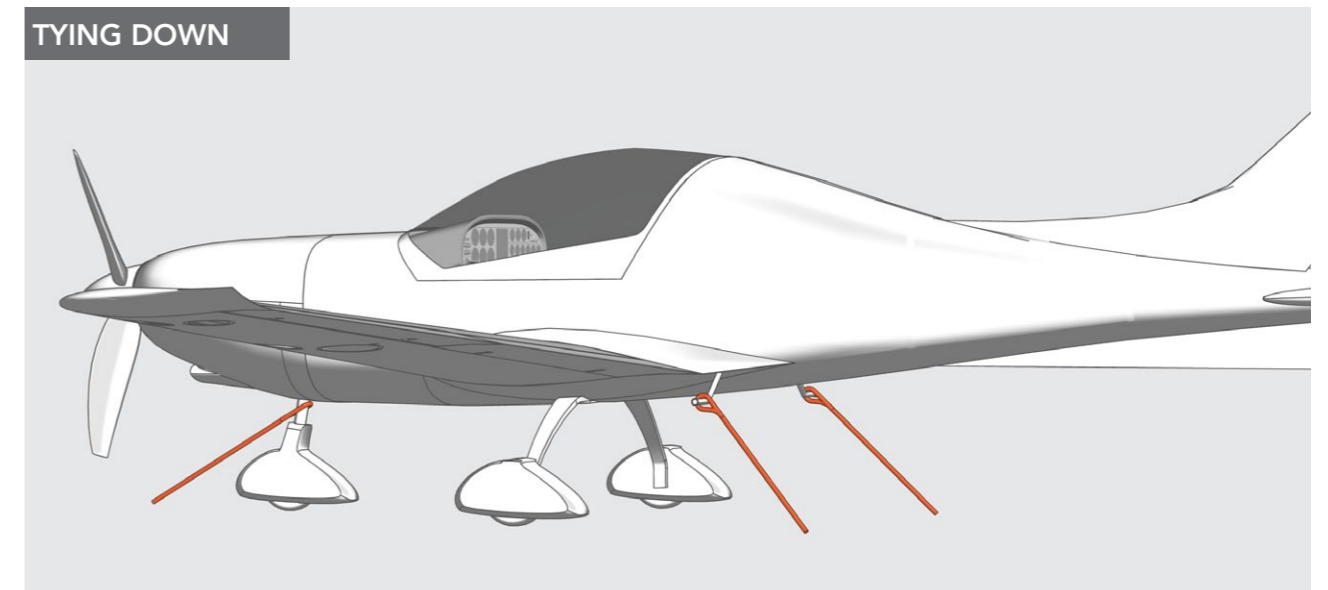

4.4. LIFTING AND LEVELLING

When jacking the airplane the following procedure should be followed:

- 1 Put a stand (under a rib) under each wing to prevent the airplane from tilting.
- 2 Locate jacks under the nose landing gear ferrule and the other each side next to the cabin walls, under the main landing gear box.
- 3 Apply wooden blocks.
- 4 Lift the airplane gradually to the required height. Lift the airplane, raising each jack evenly at the same time and avoid swaying.

After lifting, the airplane should be leveled, so that the cabin wall edges are horizontal (see the illustration).

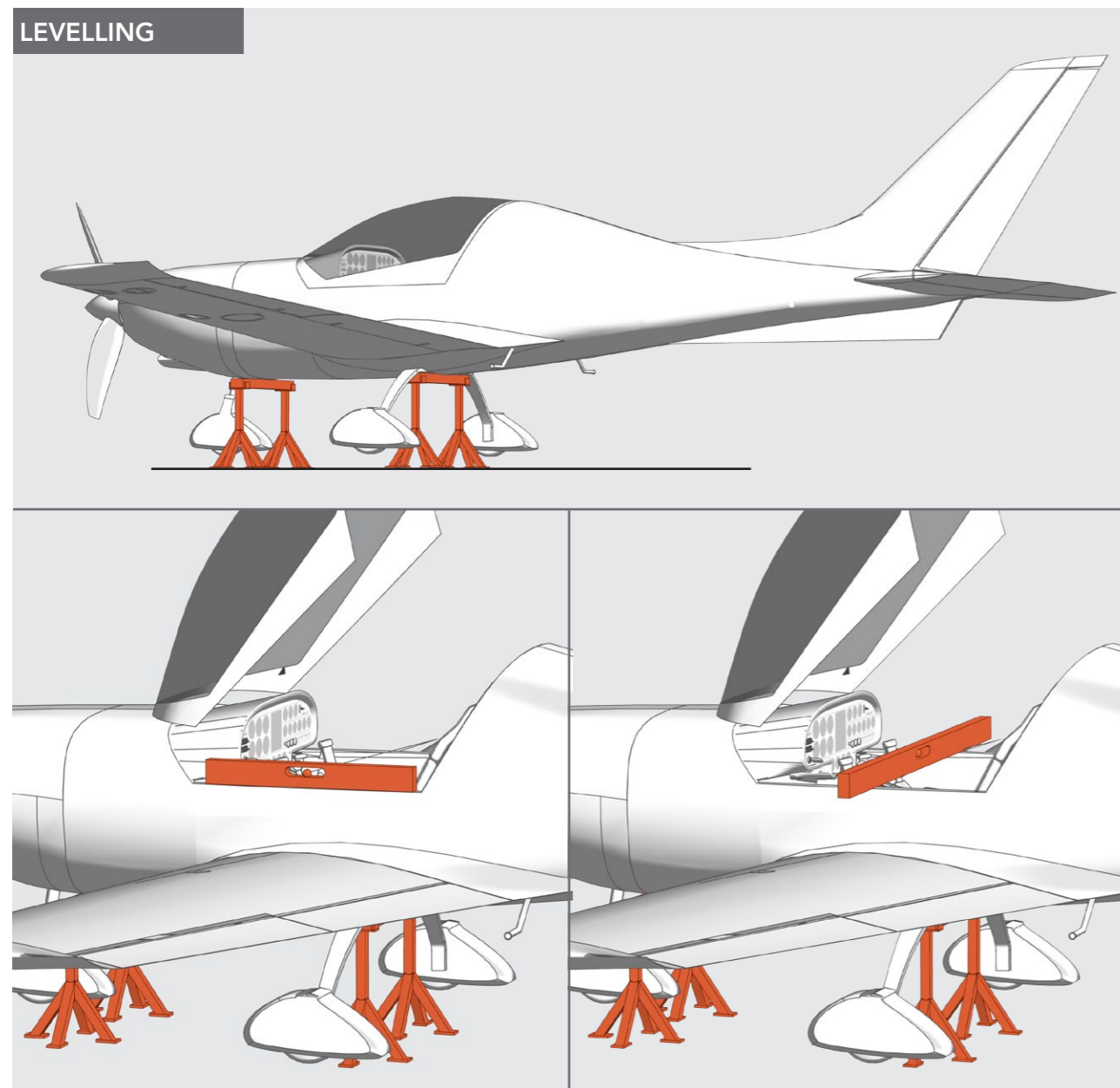

5. CLEANING AND CARE

It is essential for the reliability of the airplane components to always keep them clean.

5.1. PAINTED EXTERNAL SURFACES

Prior to clean, take the following steps

- 1 Protect the wheels, especially the brake discs, covering them.
- 2 Put the cover on the pitot and static pressure sensors.
- 3 Mask off all holes and orifices.

Use clean water to remove all fine particles and then wash the surface with water adding mild soap. Do not use detergents or soaps which are acid, alkaline or abrasive.

To remove spots of grease or oil, use a piece of cloth with degreasing solvent.

After use of degreasing solvent the surface should be re-waxed and polished.

To polish the painted surfaces, a soft cloth or chamois leather should be used.

Aged painted surfaces can be treated with automotive waxes or good quality polishing compounds.

5.2. GLASS PANELS

The greatest care should be taken to avoid scratches when cleaning glass panels of plexiglass. Never wipe the glass panels when dry. Rinse the panel with clean water or solution of mild soap and then wipe with soft clean cloth, sponge or chamois leather.

To remove films of oil or grease, use tribasic sodium phosphate, well dissolved in water.

Sediments of grease or oil, if difficult to remove, should be cleaned with methanol, hexane, or naphtha. Finally rinse with clean water avoiding excessive rubbing of the glass panel surface.

 **Caution!** Do not use petrol, benzene, acetone, anti-icing compounds, or paint solvents, because these substances soften the plexiglass, or may give rise to a network of fine cracks

5.3. PROPELLER

The propeller is to be cleaned in the same way as the painted surfaces.

5.4. ENGINE

The engine is to be cleaned as indicated in the Engine Maintenance Manual.

5.5. CABIN INTERIOR

The seats, carpets and upholstery have to be cleaned with a vacuum cleaner.

Do not use water to clean items of cloth or fabric.

Foam-based shampoos for general use on automotive upholstery may be applied, but the indications given on the packing should be strictly observed.

6. REPARATIONS

Any repair or modification of the airplane design may only be performed by authorized personnel.

 Note: prior to any modification or reparation of the airplane, consult with and obtain written approval by the manufacturer, that the intended modification will not negatively affect the airworthiness of the airplane.

After completing the modification, according to the instructions given in the Airplane Maintenance Manual, the aircraft should be re-weighed, and the respective weighing report sheet completed and the Weight and Balance schedule of this manual must be revised.

For every reparation consult with manufacturer to have the lamination and reparation plan, showing picture of the damage.

6.1. MAIN WHEELS' ASSEMBLAGE AND DISASSEMBLAGE

As for the main wheels 'assemblage and disassembling, at first remove the wheels mudguards. Then:

- 1 Put a jack under the iron tools which secure the undercarriage to the fuselage and jack the wheel up
- 2 Unhook and unscrew the spacer on the wheel axle-shaft
- 3 Remove the wheel from the axle-shaft
- 4 Wash the bearings with gasoline and dry by blowing air
- 5 Check the bearings to found out eventual damages or corrosions. In case of need, replace them
- 6 After the check-up, grease the bearings
- 7 The assemblage and the disassemblage of the wheel and of its fairing follow the reverse order with regard to the disassemblage.
- 8 Then pump the braking circuit.

PUMPING OF BRAKING CIRCUIT

The pumping of braking circuit needs two operators:

- 1 First of all, install a PVC tube on the relief valve, cleaned from dust and incrustations.
- 2 The other edge of that tube must be dipped in a container to recover the brake fluid.
- 3 An operator puts on the brake lever and keeps it locked in "brake" position until the end. The other operator, following the order of the first one, unscrews the valve of two turns and checks the flowing of air bubbles from the braking circuit.
- 4 In this way, the first operator causes the overflow of air bubbles until the stop and asks the second operator for screwing well the valve. Then he releases the brake lever.
- 5 Repeat this operation until the air bubbles stop overflowing from the PVC tube.
- 6 In the pumping of braking circuit, see the fluid level in the expansion container and, in case of need, fill up to not allow the level to go under a minimum and to avoid the air penetration in the circuit.

6.2. REPLACEMENT OF BRAKES' PADS

As for the replacement of brakes' pads and of brakes' discs, follow these steps:

- 1 Remove the wheel
- 1 Disconnect the wheel from the brake disc and from the support
- 2 Dismantle the calliper
- 3 Replace the brakes' pads in the support and the brake discs, when they are worn out.

6.3. REPLACEMENT OF THE MAIN WHEEL'S TYRE

To replace the tyre:

- 1 Empty the air from the tyre
- 2 Remove the tyre from the rim
- 3 Push the valve in the rim hole and remove the inner tube (if it's present)
- 4 Check the rim, clean it
- 5 Dry-clean the internal surface of the tyre
- 6 Put the tyre again (with the eventual inner tube) in the rim
- 7 Inflate the tyre till the adequate pressure (2,0-2,2 kgf/cm², approximately 2 bar).

6.4. MATERIALS USED IN MANUFACTURING PROCESS

Composite parts are made of (usable for small repairs):

Carbon fibre	200 g/m ² Plain
Glass fibre	300 g/m ² Twill; 200 g/m ² Plain; 160 g/m ² Twill; 80 g/m ² Plain
Foam	60 kg/m ³ PVC 3 mm, 5 mm, 10 mm, 15 mm, 25 mm
Resin	Epoxy resin
Filler for bonding	Microfibres; cab-o-sil; glass bouble
Paint	Gelcoat
Heat resistant protection	Glass-aluminium-stainless steel sandwich

All parts are made in moulds, therefore no shape or structural differences can occur.

7. INFORMATION SIGNS AND MARKINGS

This chapter describes the labels and the location of signs are described on the aircraft.

7.1. PANEL

All designations for switches, controls and fuses are printed directly on the panel. The printing depends on the cockpit configuration.

Example of an analog configuration:

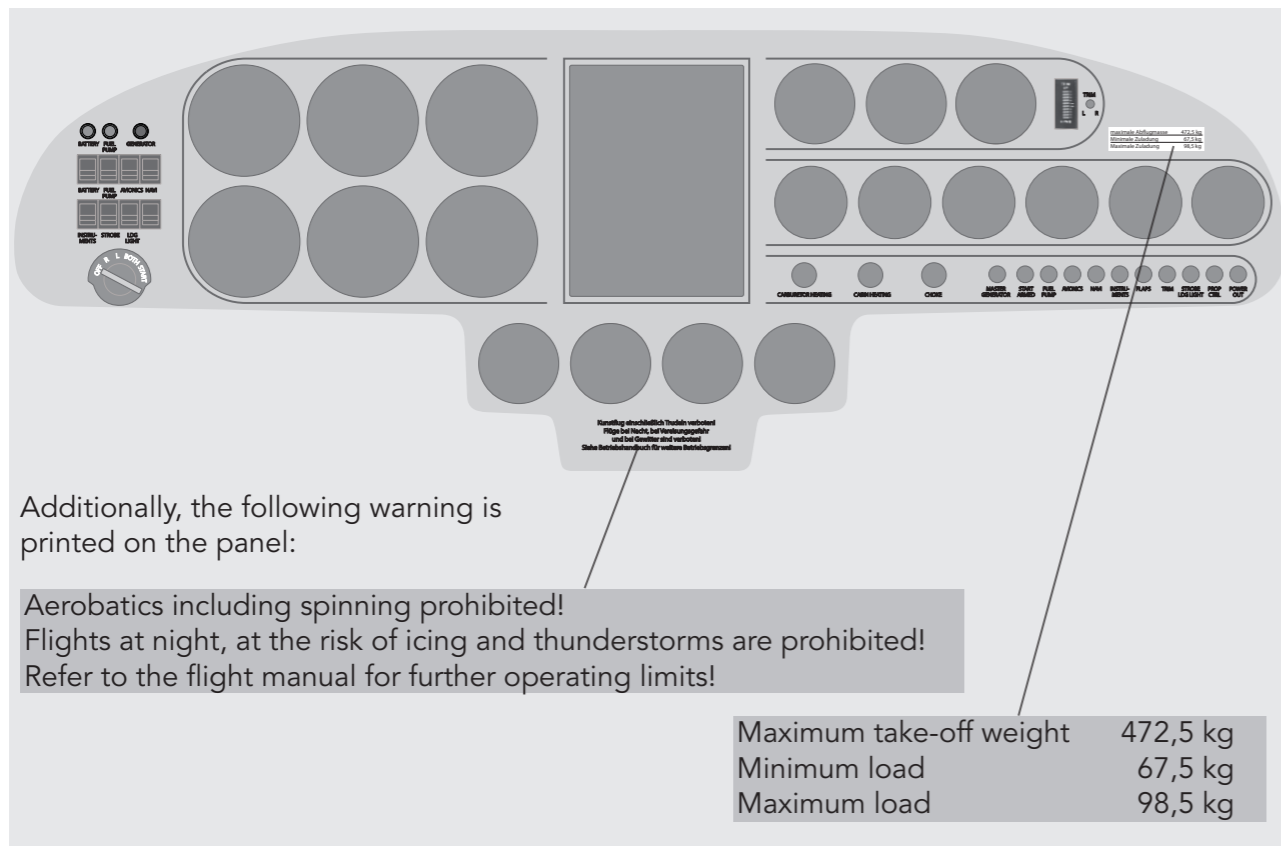

The warnings may vary according to configuration are also available at other locations of the panel, however, are always clearly visible to the pilot and may not be removed.

7.2. FURTHER MARKINGS

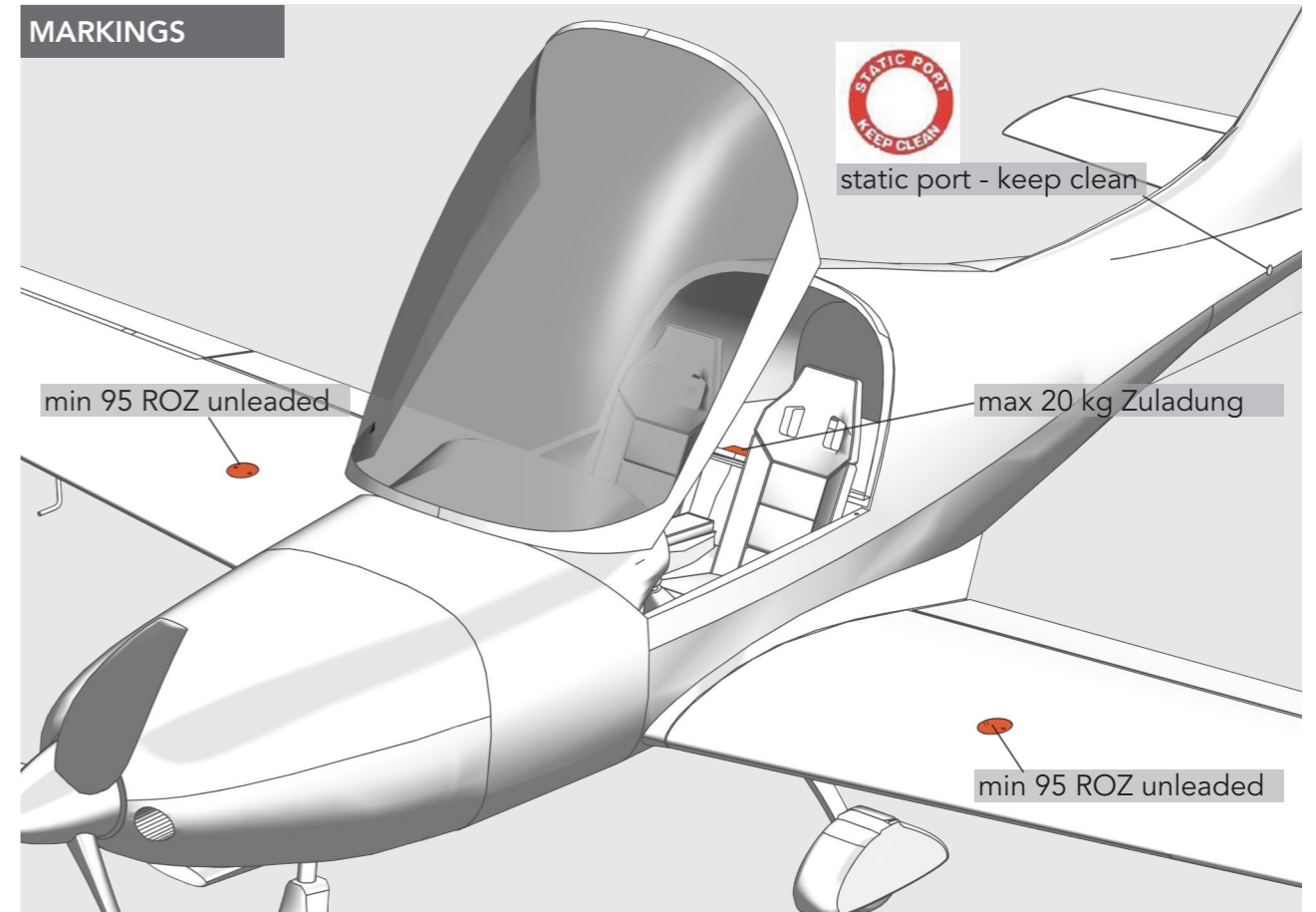

Tankcover: min 95 ROZ unleaded
Baggage compartment: max 20 kg load
Static port - keep clean

7.3. AIRSPEED INDICATOR MARKS

Marking	IAS (km/h)	Remark
White arc	69 – 119	Operating range with full flaps extended
Green arc	94 – 200	Normal operating range
Yellow arc	200 - 274	Caution range, only in good weather condition
Yellow line	170	Max. maneuver speed
Red line	274	Never exceed speed

8. RESCUE SYSTEM

8.1. TECHNICAL DATA OF THE MAGNUM LIGHT SPEED SOFTPACK

Length of container	340 mm
Width of container	240 mm
Thickness of container	190 mm
Total weight	9.65 kg
Area of canopy	86 m ²
Number of cords	32
Max tested operating speed	300 km/h
average descent rate by 475 kg	7.33 m/s
Opening time at standard speed min 100 km/h	3.9 s
Rocket container diameter	60 mm
Rocket container length	270 mm

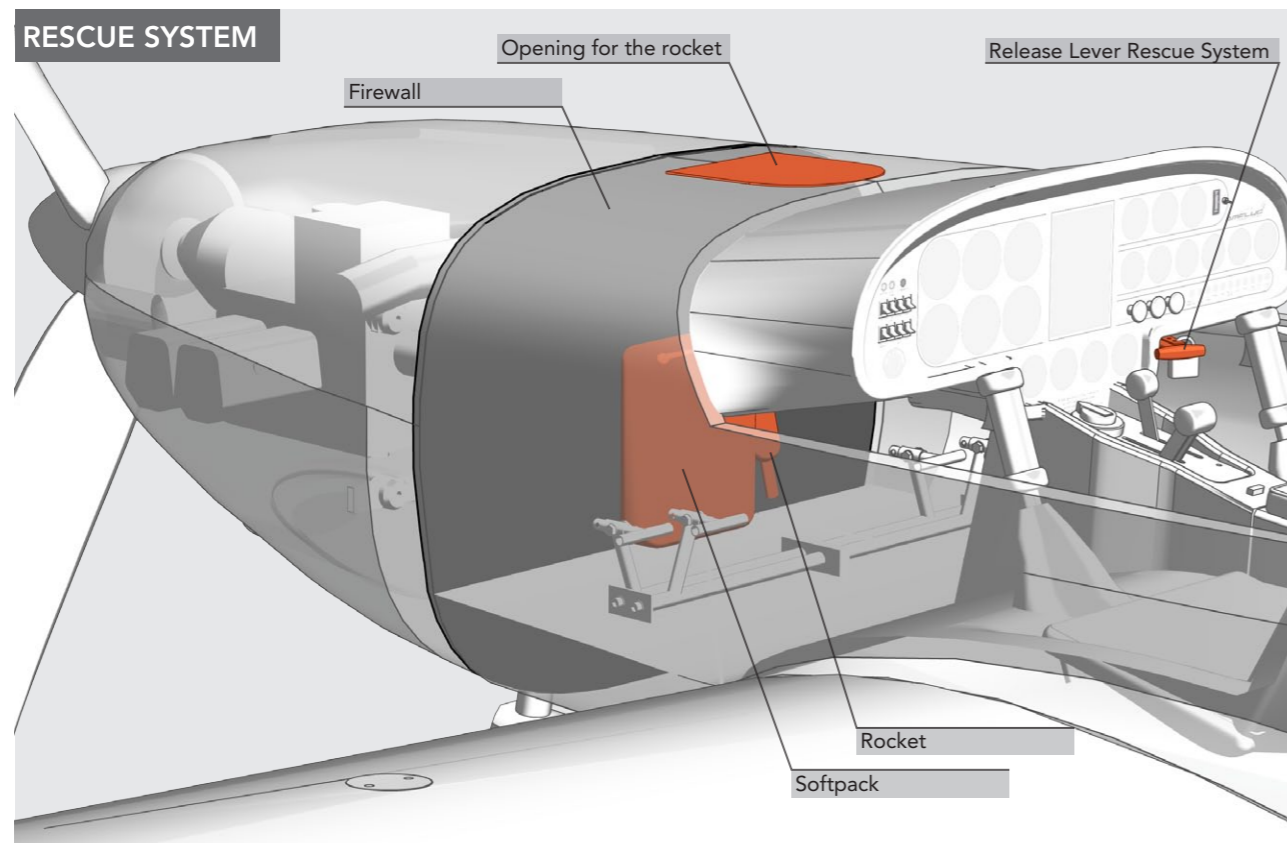

8.2. INSTALLATION DRAWINGS

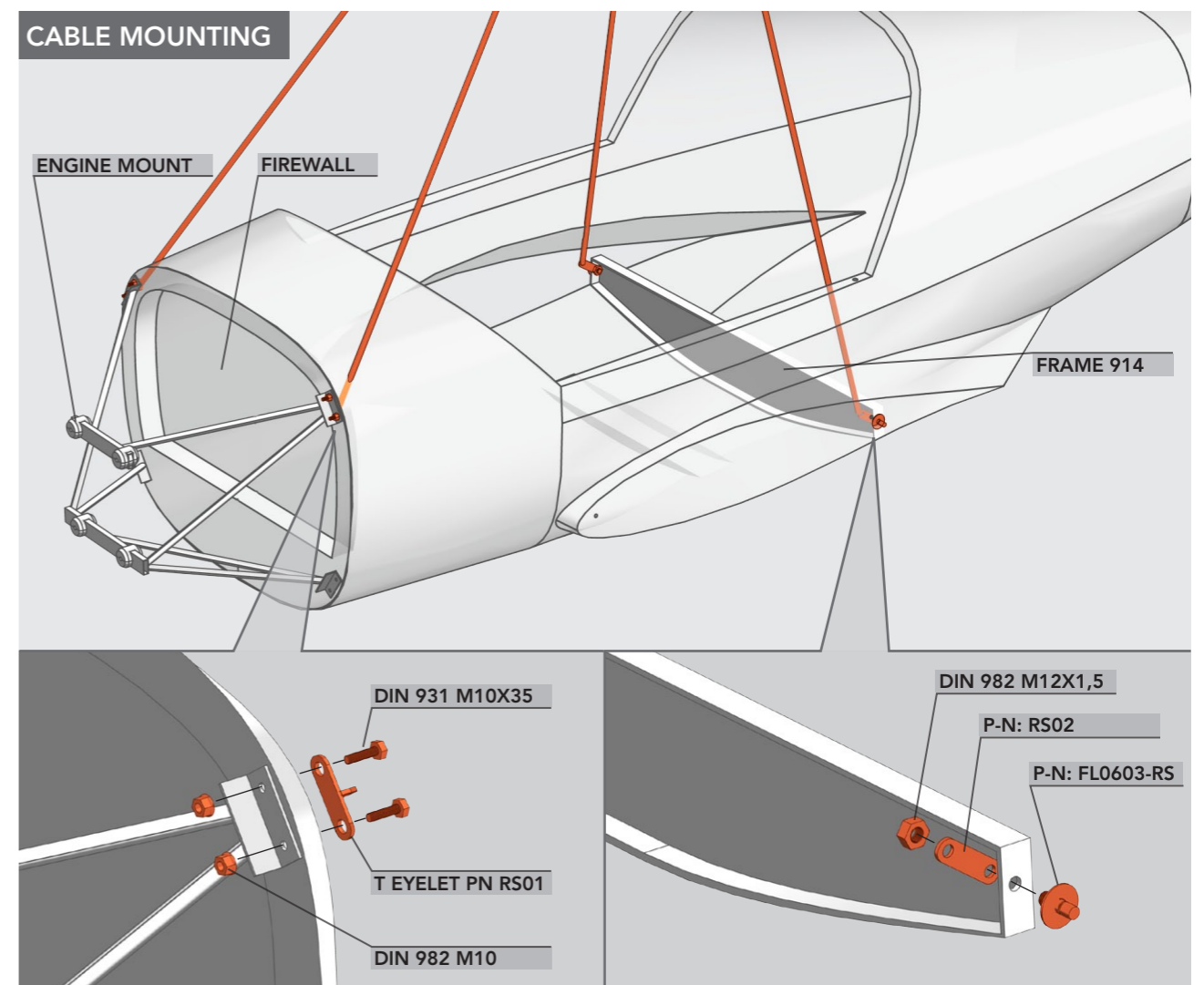
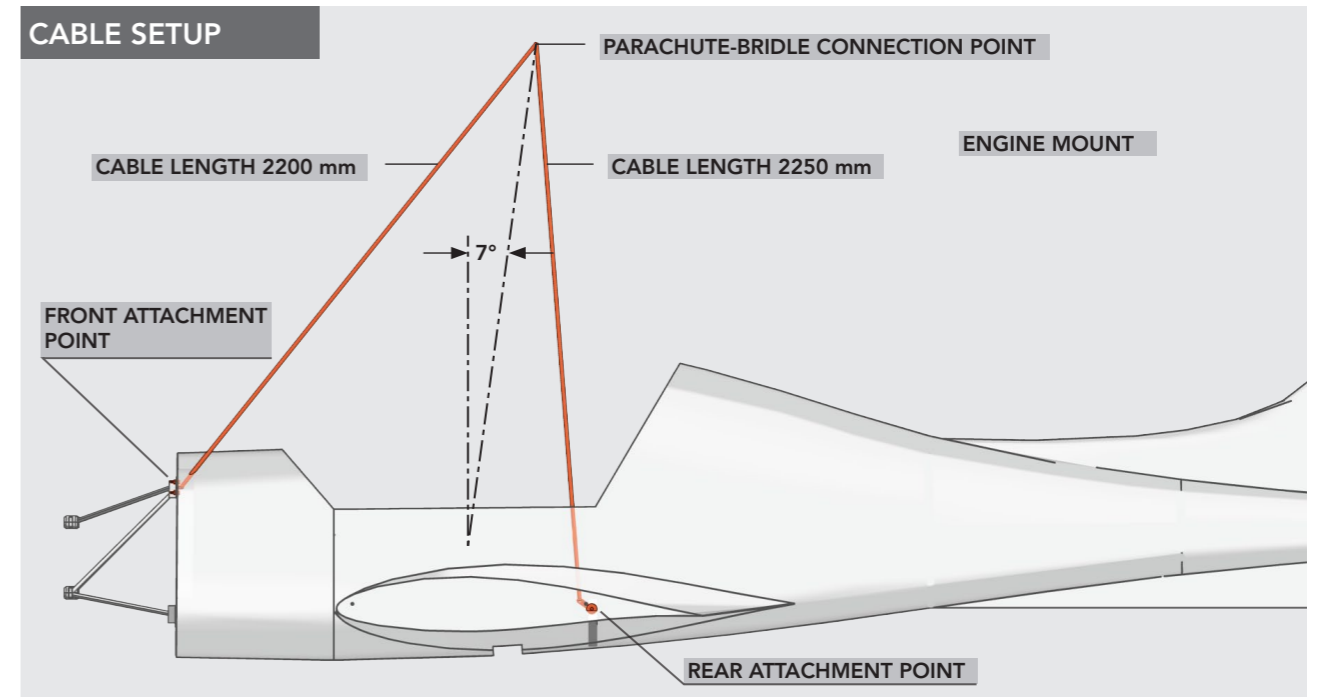

8.3. MAINTENANCE OF THE MAGNUM LIGHT SPEED SOFTPACK

Throughout the dismantling – or assembly process never use violence or bring tension on the activation cord! All steps must be made smooth. Otherwise the rocket will activate!

During your work put the shooting out opening always away from yourself and check before starting work that there are no persons or object in shooting out opening! If possible, all works should be done outside.

Please note, that for all works done yourself are without warranty of function or security, besides they have been proved by anybody authorized from Junkers Profly GmbH.

All work done by yourself are at your own risk and responsibility.

The rescue system is free of maintenance works (if used appropriately) for the duration of 6 years.

After activating the system or after this span of 6 years, the rescue system has to be sent to the manufacturer.

This check may only be executed by the manufacturer.

For every damage during the use, which might endanger the safety of the product, Junkers Profly assures repair of the rescue system and its reduction into the original condition. Every damage must be communicated to Junkers Profly.

It is recommended to change all fixing cords out of Kevlar or Polyamide after 12 years or after 18 years.

8.4. MAINTENANCE DURING STORAGE

After air traffic the system has to be saved with transport lock.

It is approved to connect transport lock with firing key.

Therefore you avoid that the rescue system is locked mistaken during the flight.

In case of long term storage the rescue system should kept under dry and room temperature conditions.

Other maintenance works will not be necessary.

9. WEIGHING PROCEDURE

This Section contains the limitations of the useful load, within which the airplane may be operated safely.

Loading condition of the aircraft during weighing:

Equipment as per Equipment Inventory.

Including lubricants.

Petrol tank is empty (except for the residual amount).

When weighing the aircraft in both axes must be horizontal.

Horizontal reference line is the lower cockpit entry edge.

Reference point is the front wing edge at the transition to the fuselage.

Airplane against rolling off.

Under each wheel fix a weighing scale and determine the weights.

WEIGHING PROCEDERE

BE Reference Plane
BP Reference Point
BL horizontal Reference Line

S Center of Gravity Arm
G₃ Weight Frontwheel
G_{Li} Weight Mainwheel left
G_{Re} Weight Mainwheel right

X₃ Moment Frontwheel - 850 mm
X_{Li} Moment Mainwheel left 650 mm
X_{Re} Moment Mainwheel right 605 mm

Calculation Center of Gravity Arm:

$$CG = \frac{G_{Li} \times X_{Li} + G_{Re} \times X_{Re} + G_3 \times X_3}{G_{Li} + G_{Re} + G_3}$$

Center of Gravity Arm

at 290 kg 178 - 206 mm

at 340 kg 188 - 233 mm

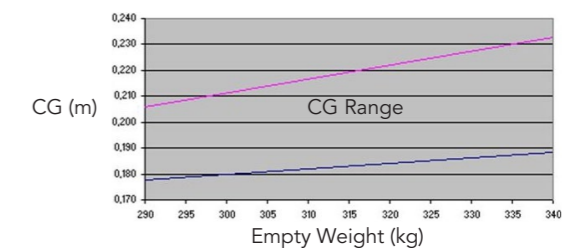

The CG is in the weight and balance. If changes to the equipment to be made, a new weighing with the determination of the CG must be done.

